

TECHNICAL MANUAL

**TRANSPORTABILITY GUIDANCE
TEAMPACK RECEIVING SETS
AN/MSQ-103A/C RECEIVING SETS
AN/MSQ-103B LIGHTWEIGHT RECEIVING SET**

APPROVED FOR PUBLIC RELEASE; DISTRIBUTION IS UNLIMITED

HEADQUARTERS, DEPARTMENT OF THE ARMY

MARCH 1989

TECHNICAL MANUAL }
 No. 55-5811-188-14 }

HEADQUARTERS
 DEPARTMENT OF THE ARMY
 WASHINGTON, DC, 24 March 1989

**TRANSPORTABILITY GUIDANCE
 TEAMPACK RECEIVING SETS
 AN/MSQ-103A/C RECEIVING SETS
 AN/MSQ-103B LIGHTWEIGHT RECEIVING SET**

		<i>Paragraph</i>	<i>Page</i>
Chapter	1. INTRODUCTION		
	Purpose and Scope	1-1	1-1
	Safety	1-2	1-1
	Definitions of Warnings, Cautions, and Notes.....	1-3	1-1
	Reporting of Recommendations and Comments	1-4	1-1
Chapter Section	2. TRANSPORTABILITY DATA		
	I. GENERAL		
	Scope	2-1	2-1
	Description	2-2	2-1
	II. CHARACTERISTICS AND RELATED DATA		
	General.....	2-3	2-1
	Transportability Drawings	2-4	2-3
	Unusual Characteristics	2-5	2-3
	Hazardous and Dangerous Characteristics	2-6	2-3
Chapter	3. SAFETY		
	General.....	3-1	3-1
	Specific Safety Requirements	3-2	3-1
Chapter Section	4. AIR TRANSPORTABILITY GUIDANCE		
	I. GENERAL		
	Scope	4-1	4-1
	Maximum Utilization of Aircraft	4-2	4-1
	Safety	4-3	4-1
	Responsibility	4-4	4-1
	II. TRANSPORT BY US AIR FORCE AIRCRAFT		
	Transportability	4-5	4-1
	Tiedown Data.....	4-6	4-2
Chapter Section	5. HIGHWAY TRANSPORTABILITY GUIDANCE		
	I. GENERAL		
	Scope	5-1	5-1
	Safety	5-2	5-1
	Self-Propelled Movement	5-3	5-1
	Transport by Semitrailers	5-4	5-1
	II. PREPARATION, LOADING, UNLOADING, AND MATERIALS FOR TRANSPORT ON A SEMITRAILER		
	Preparation	5-5	5-1
	Loading, Unloading, and Materials	5-6	5-1
Chapter Section	6. MARINE AND TERMINAL TRANSPORTABILITY GUIDANCE		
	I. GENERAL		
	Scope	6-1	6-1
	Safety	6-2	6-1
	II. LOADING AND SECURING		
	Transportability	6-3	6-1
	General Rules for Stowage	6-4	6-1
Chapter Section	7. RAIL TRANSPORTABILITY GUIDANCE		
	I. GENERAL		
	Scope	7-1	7-1

APPROVED FOR PUBLIC RELEASE: DISTRIBUTION IS UNLIMITED

		<i>Paragraph</i>	<i>Page</i>
	Maximum Utilization of Railcars	7-2	7-1
	Safety.....	7-3	7-1
II.	TRANSPORT ON CONUS RAILWAYS		
	General	7-4	7-1
	Loading on Wood-Deck Flatcars	7-5	7-1
	Loading on Flatcars with Steel Decks and Center Tiedown Rails	7-6	7-10
III.	TRANSPORT ON FOREIGN RAILWAYS		
	General	7-7	7-10
	Transport on Foreign Flatcars	7-8	7-14
Appendix	References		A-1

LIST OF ILLUSTRATIONS

<i>Figure</i>	<i>Title</i>	<i>Page</i>
2-1	Transport configuration of the AN/MSQ-103A shelter	2-4
2-2	Transport configuration of the AN/MSQ-103C shelter	2-5
2-3	Transport configuration of the M1015 tracked cargo carrier	2-6
2-4	Transport configuration of the M925A1 5-ton truck	2-7
2-5	TEAMPACK AN/MSQ-103A shelter mounted on the M1015 carrier	2-8
2-6	TEAMPACK AN/MSQ-103C shelter mounted on the M1015 carrier	2-9
2-7	AN/MSQ-103B lightweight TEAMPACK shelter	2-10
2-8	AN/MSQ-103B lightweight TEAMPACK shelter mounted in the M1028 CUCV	2-11
4-1	Tiedown diagram for M1015 carrier in C-5 aircraft.....	4-3
4-2	Tiedown diagram for M1015 carrier in C-130 and C-141 aircraft	4-4
4-3	Tiedown diagram for shelters on two interlocked 463L pallets	4-6
4-4	Tiedown diagram of CUCV in C-130 and C-141 aircraft	4-7
4-5	Tiedown diagram of CUCV in C-5 aircraft	4-8
5-1	Tiedown of the TEAMPACK on the M172A1 semitrailer	5-4
5-2	Dimensions of the M172A1 semitrailer and the TEAMPACK mounted on the M172A1 semitrailer	5-5
5-3	Typical tiedown of the CUCV on a semitrailer.....	5-6
6-1	Lifting diagram for M1015 carrier without shelter attached	6-2
6-2	Lifting diagram for M1015 carrier with shelter attached, by use of lifting beam and wire-rope slings with spreader bar	6-3
6-3	Lifting diagram for -103C TEAMPACK shelter	6-4
6-4	CUCV lifted by a four-legged sling and a spreader bar	6-6
6-5	Typical blocking of TEAMPACK carrier in hold of general-cargo vessel	6-7
6-6	Typical blocking of lightweight TEAMPACK system in hold of general-cargo vessel	6-8
6-7	Typical tiedown of tracked cargo carrier on RORO vessel, showing typical securement with patented lashing	6-10
6-8	Typical tiedown of CUCV in RORO vessel.....	6-10
6-9	Typical loading of five TEAMPACK carriers on a LASH, by use of wire rope, cable clips, and turnbuckles, with blocking between vehicles and between vehicles and hull	6-11
6-10	Filling center void or TEAMPACK-to-hull void area	6-12
6-11	Typical blocking and tiedown of lightweight TEAMPACK in SEABEE barge	6-13
7-1	Blocking and tiedown of M1015 carrier on wood-deck flatcar	7-2
7-2	Blocking and tiedown of M1028 CUCV on wood-deck flatcar	7-3
7-3	Blocking and tiedown details	7-4
7-4	Blocking and tiedown of three TEAMPACK shelters on wood-deck flatcar	7-8
7-5	Blocking and tiedown of six lightweight TEAMPACK shelters on wood-deck flatcar	7-9
7-6	Tiedown of M1015 carrier on steel-deck, center-rail flatcar	7-12
7-7	Tiedown of M1028 CUCV on steel-deck, center-rail flatcar	7-13

LIST OF TABLES

<i>Table</i>	<i>Title</i>	<i>Page</i>
4-1	Tiedown Data for M1015 Carrier in C-5 Aircraft (Fig 4-1)	4-2
4-2	Tiedown Data for M1015 Carrier in C-130 and C-141 Aircraft (Fig 4-2)	4-2
4-3	Tiedown Data for TEAMPACK Shelters Secured to Two Interlocked 463L Pallets (HUC 61E) (Fig 4-3)	4-5
4-4	Tiedown Data for CUCV in USAF C-130 and C-141 Aircraft (Fig 4-4)	4-5
4-5	Tiedown Data for CUCV in USAF C-5 Aircraft (Fig 4-5)	4-5
5-1	Bill of Materials for Tiedown of TEAMPACK on M172A1 Semitrailer (Fig 5-1)	5-2
5-2	Application of Materials for Tiedown of TEAMPACK on M172A1 Semitrailer (Fig 5-1)	5-2
5-3	Bill of Materials for Tiedown of CUCV on Semitrailer (Figure 5-3)	5-2

<i>Table</i>	<i>Title</i>	<i>Page</i>
5-4	Application of Materials for Tiedown of CUCV on Semitrailer (Fig 5-3)	5-3
6-1	Bill of Materials for Blocking of TEAMPACK Carrier in Hold of General-Cargo Vessel (Fig 6-5)	6-5
6-2	Application of Material for Blocking of TEAMPACK Carrier in Hold of General-Cargo Vessel (Fig 6-5) ..	6-5
6-3	Bill of Materials for Blocking of Lightweight TEAMPACK System in General-Cargo Vessel (Fig 6-6) ..	6-5
6-4	Application of Materials for Blocking of Lightweight TEAMPACK System in General-Cargo Vessel (Fig 6-6)	6-9
7-1	Bill of Materials for Blocking and Tiedown of M1015 Carrier on Wood-Deck Flatcar (Fig 7-1)	7-5
7-2	Application of Materials for Blocking and Tiedown of M1015 Carrier on Wood-Deck Flatcar (Fig 7-1) .	7-5
7-3	Bill of Materials for Blocking and Tiedown of CUCV on Wood-Deck Flatcar (Fig 7-2)	7-6
7-4	Application of Materials for Blocking and Tiedown of CUCV on Wood-Deck Flatcar (Fig 7-2)	7-6
7-5	Bill of Materials for Blocking and Tiedown of Three TEAMPACK Shelters on Wood-Deck Flatcar (Fig 7-4)	7-7
7-6	Application of Materials for Blocking and Tiedown of Three TEAMPACK Shelters on Wood-Deck Flatcar (Fig 7-4)	7-7
7-7	Bill of Materials for Blocking and Tiedown of Six Lightweight TEAMPACK Shelters on Wood-Deck Flatcar (Fig 7-5)	7-10
7-8	Application of Materials for Blocking and Tiedown of Six Lightweight TEAMPACK Shelters on Wood-Deck Flatcar (Fig 7-5)	7-10
7-9	Application of Chain Tiedown for Securing M1015 Carrier on Steel-Deck, Center-Rail Flatcar (Fig 7-6)	7-11
7-10	Application of Chain Tiedown for Securing CUCV on Steel-Deck, Center-Rail Flatcar (Fig 7-7)	7-11

CHAPTER 1 INTRODUCTION

1-1. Purpose and Scope

a. This manual provides transportability guidance for logistical handling and movement of the AN/MSQ-103A, -103B, and -103C models of the TEAMPACK.

b. This manual provides guidance for safe transport of vehicles and shelters. It includes significant technical and physical characteristics as well as safety precautions required for worldwide movement by the various modes of transportation. This manual is intended for transportation officers and other personnel responsible for movement or for providing transportation services.

c. Where appropriate, metric equivalents are given in parentheses following dimensions or other measurements. References are cited in the appendix.

1-2. Safety

Appropriate precautionary measures required during movement of the items are contained in chapter 3.

1-3. Definitions of Warnings, Cautions, and Notes

Throughout this manual, warnings, cautions, and notes

emphasize important or critical guidance. They are used for the following conditions:

a. *Warning.* Instructions that, if not correctly followed, could result in injury to or death of personnel.

b. *Caution.* Instructions that, if not strictly observed, could result in damage to, or destruction of, equipment.

c. *Note.* An operating procedure or condition that must be emphasized.

1-4. Reporting of Recommendations and Comments

Users of this manual are encouraged to submit comments and to recommend changes for its improvement. Comments and recommendations should be prepared on DA Form 2028 (Recommended Changes to DA Publications and Blank Forms) and forwarded to Commander, Military Traffic Management Command Transportation Engineering Agency, ATTN: MTT-TRV, PO Box 6276, Newport News, VA 23606-0276. Electrically transmitted messages should be addressed to CDR MTMC TEA FT EUSTIS VA//MTT-TRV//. A reply will be furnished by this command.

CHAPTER 2
TRANSPORTABILITY DATA

Section I. GENERAL

2-1. Scope

This chapter provides a general description of the items. It also provides identification photographs, transportability characteristics, and data that are necessary in the movement of the items.

housed in S-623 (modified S-280) equipment shelters. The TEAMPACK shelters may also be transported by the M925A1 5-ton cargo truck. Currently, there are very few TEAMPACK shelters transported by 5-ton trucks. Programs to replace these 5-ton trucks with M1015's are underway.

2-2. Description

a. The AN/MSQ-103A/C TEAMPACK systems are tactical, noncommunication, intercept, identification, and direction-finding receiving sets. These systems are

b. The AN/MSQ-103B lightweight TEAMPACK is a special-purpose receiving set housed in an S-684 (modified S-250) equipment shelter. The M1028 commercial utility cargo vehicle (CUCV) is the prime mover for the lightweight TEAMPACK shelter.

Section II. CHARACTERISTICS AND RELATED DATA

2-3. General

The following characteristics and data are applicable to the equipment that is necessary for the movement of the TEAMPACK systems.

a. AN/MSQ-103A TEAMPACK System.

	<i>M1015</i>	<i>M925A1</i>
Line item number	R39883	R39883
Performance:		
Maximum speed	40 mph (64 km/h)	63 mph (101 km/h)
Maximum grade	60 pct	NA
Cruising range	300 mi (483 km)	300 mi (483 km)
Fuel tank capacity	105 gal (397 L)	81 gal (307 L)
Turning radius	pivot	38 ft (11.58 m)
Angle of approach	22.5°	46°
Angle of departure	13.5°	37°
Ground clearance	16.0 in. (0.41 m)	13.1 in. (0.33 m)
Dimensions and shipping data:		
Length	245.0 in. (6.22 m)	332.0 in. (8.43 m)
Width	106.0 in (2.69 m)	97.4 in. (2.47 m)
Height:		
Operational	141.0 in. (3.58 m)	150.0 in. (3.81 m)
Reduced	NA	123.0 in. (3.12 m)
Antenna removed	114.0 in. (2.90 m)	NA
Curb weight:		
Fully equipped, less payload and crew:		
Front	NA	11,255 lb (5110 kg)
Rear	NA	11,020 lb (5003 kg)
Total	NA	22,275 lb (10 113 kg)
Payload	NA	10,000 lb (4540 kg)
With shelter and crew:		
Front	NA	11,089 lb (5034 kg)
Rear	NA	20,046 lb (9101 kg)
Total	NA	31,135 lb (14 135 kg)

	<i>M1015</i>	<i>M925A1</i>
Gross weight	25,724 lb (11 679 kg)	NA
Center of gravity:		
From centerline of drive sprocket	106.68 in. (2.71m)	NA
Rear of centerline of front axle	NA	115 in. (2.92 m)
Above ground	49.68 in. (1.26 m)	NA

b. ANMSQ-103C TEAMPACK System.

	<i>M1015</i>	<i>M925A1</i>
Line item number	R39883	R39883
Performance:		
Maximum speed	40 mph (64 km/h)	63 mph (101 km/h)
Maximum grade	60 pct	NA
Cruising range	300 mi (483 km)	300 mi (483 km)
Fuel tank capacity	105 gal (397 L)	81 gal (307 L)
Turning radius	pivot	38 ft (11.58 m)
Angle of approach	22.5°	46°
Angle of departure	13.5°	37°
Ground clearance	16.0 in. (0.41 m)	13.1 in. (0.33 m)
Dimensions and shipping data:		
Length	245.0 in. (6.22 m)	332.0 (8.43 m)
Width	106.0 in. (2.69 m)	97.4 in. (2.47 m)
Height:		
Operational	147.0 in. (3.73 m)	156.0 in. (3.96 m)
Reduced	NA	128.0 in. (3.25 m)
Antenna removed	120.0 in. (3.05 m)	NA
Curb weight:		
Fully equipped, less payload and crew:		
Front	NA	11,255 lb (5110 kg)
Rear	NA	11,020 lb (5003 kg)
Total	NA	22,275 lb (10 113 kg)
Payload	NA	10,000 lb (4540 kg)
With shelter and crew:		
Front	NA	11,081 lb (5031 kg)
Rear	NA	20,134 lb (9141 kg)
Total	NA	31,215 lb (14 172 kg)
Gross weight	25,804 lb (11 715 kg)	NA
Center of gravity:		
From centerline of drive sprocket	106.68 in. (2.71 m)	NA
Rear of centerline of front axle	NA	115 in. (2.92 m)
Above ground	49.68 in. (1.26 m)	NA

c. AN/TSQ-103A TEAMPACK Shelter (Transport Configuration).

Dimensions and shipping data:	
Length	149.5 in. (3.80 m)
Width	86.6 in. (2.20 m)
Height:	
Overall	102.4 in. (2.60 m)
Reduced	75.0 in. (1.91 m)
Weight	3,970 lb (1802 kg)
Center of gravity (without generator and skids):	
Above ground	39.4 in. (1.00 m)
From the rear edge	38.9 in. (0.99 m)

d. AN/MSQ-103C TEAMPACK Shelter (Transport Configuration).

Dimensions and shipping data:	
Length	149.5 in. (3.80 m)
Width	91.0 in. (2.31 m)
Height:	
Overall	108.5 in. (2.76 m)
Reduced	81.0 in. (2.06 m)
Weight	7,130 lb (3237 kg)
Center of gravity (without generator and skids):	
Above ground	39.4 in. (1.00 m)
From the rear edge	38.9 in. (0.99 m)

e. AN/MSQ-103B Lightweight TEAMPACK

System (M1028)

Performance:

Maximum speed	55 mph (88.5 km/h)
Cruising range	250 mi (402 km)
Fuel tank capacity.....	27 gal (102 L)
Ground clearance:	
Front.....	8.6 in. (0.22 m)
Rear.....	7.8 in. (0.20 m)

Dimensions and shipping data:

Length	220.7 in. (5.61 m)
Width.....	86.0 in. (2.18 m)
Height.....	102.0 in. (2.59 m)

Curb weight:

Front.....	3,680 lb (1671 kg)
Rear.....	4,980 lb (2261 kg)
Total	8,660 lb (3932 kg)
With two-man crew and troop	
support equipment	9,340 lb (4240 kg)

Airlift maximum weight..... 9,400 lb (4268 kg)

Lift and tow hook's rated

working capacity	6,500 lb (2951 kg)
------------------------	--------------------

Center of gravity:

Above ground	36.5 in. (0.93 m)
Forward of rear axle.....	49.5 in. (1.26 m)

f. AN/MSQ-103B Lightweight TEAMPACK

Shelter

Dimensions and shipping data:

Length	105.4 in. (2.68 m)
Width.....	81.5 in. (2.07 m)
Height.....	68.0 in. (1.72 m)
Weight.....	2,682 lb. (1219 kg)

Center of gravity:

Above ground	35.1 in. (0.89 m)
Forward of rear axle	48.6 in. (1.23 m)

2-4. Transportability Drawings

Transportability drawings of the vehicles and shelters, with dimensions required for determining the loadability of the vehicles by various modes, are shown in figures 2-1 through 2-8.

2-5. Unusual Characteristics

The vehicles have no unusual characteristics that require special attention be given to temperatures, atmospheric pressure, or humidity variations during exposure to the normal transportation environment.

2-6. Hazardous and Dangerous Characteristics

Unless vehicles are shipped with ammunition, they will not present any special hazardous or dangerous characteristics during their exposure to the normal transportation environment.

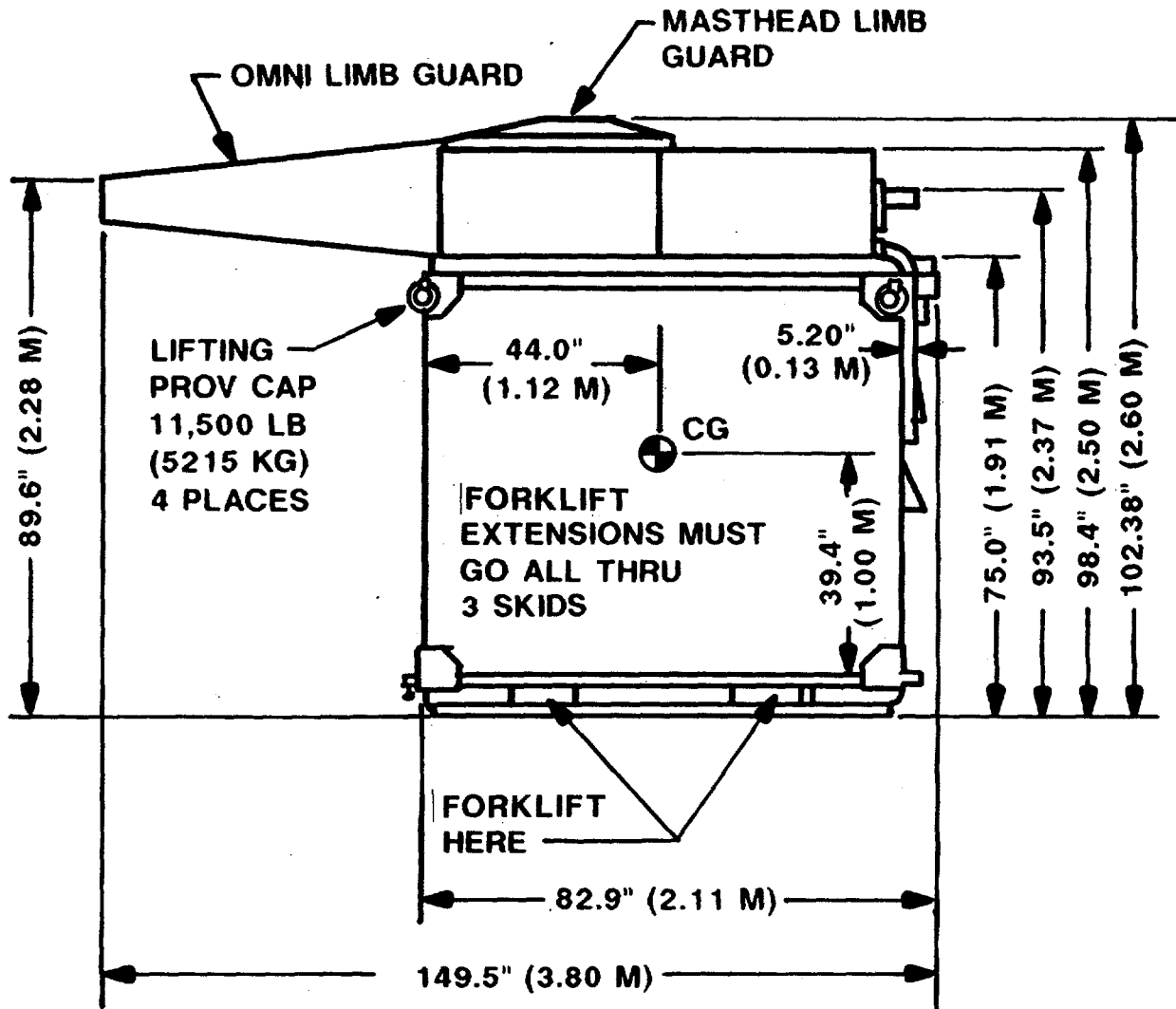

NOTE: THE MEP-112 GENERATOR AND STAND ARE TRANSPORTED SEPARATELY FROM THE AN/MSQ-103A SHELTER.

Figure 2-1. Transport configuration of the AN/MSQ-103A shelter.

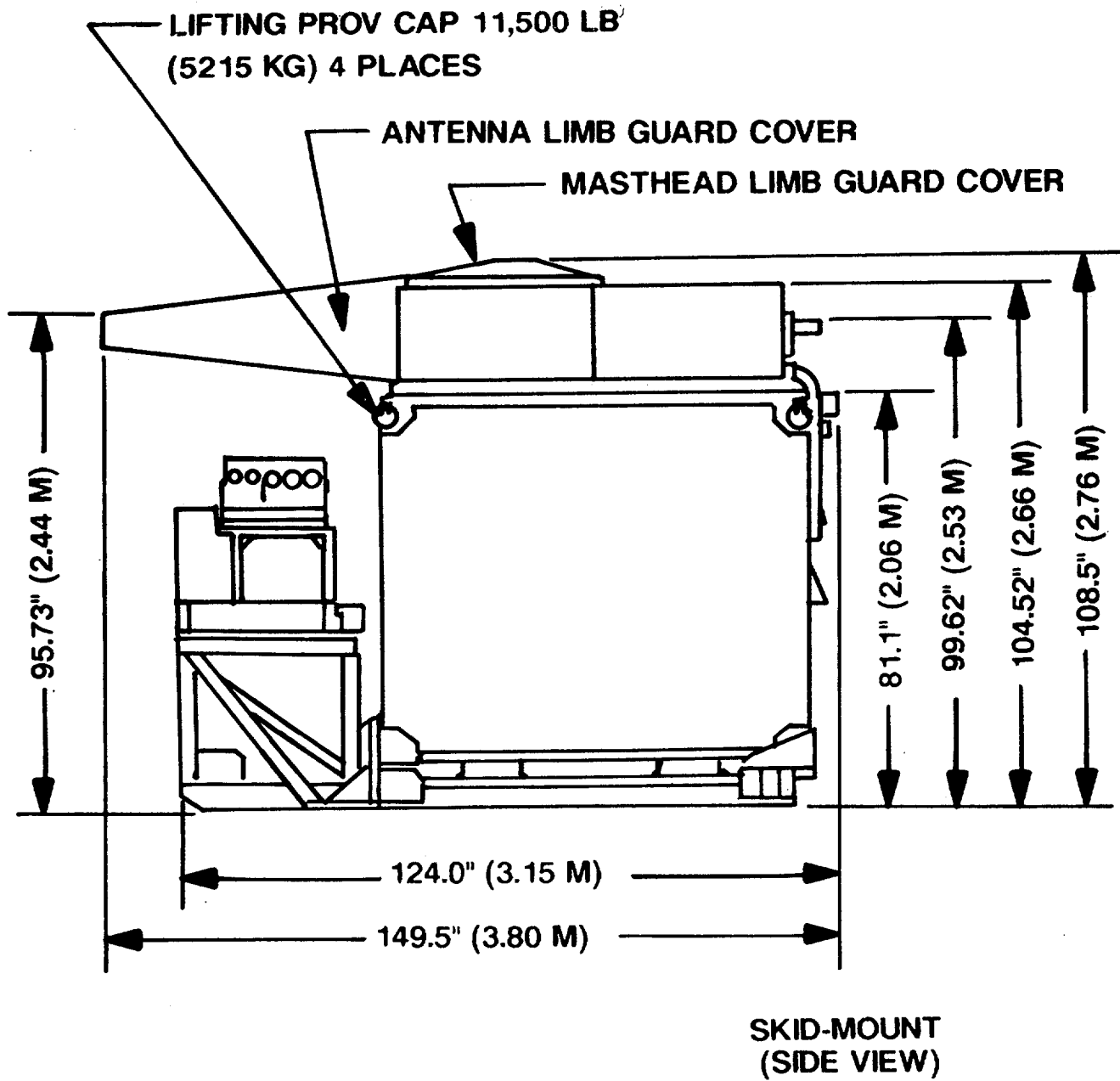

Figure 2-2. Transport configuration of the AN/MSQ-103C shelter.

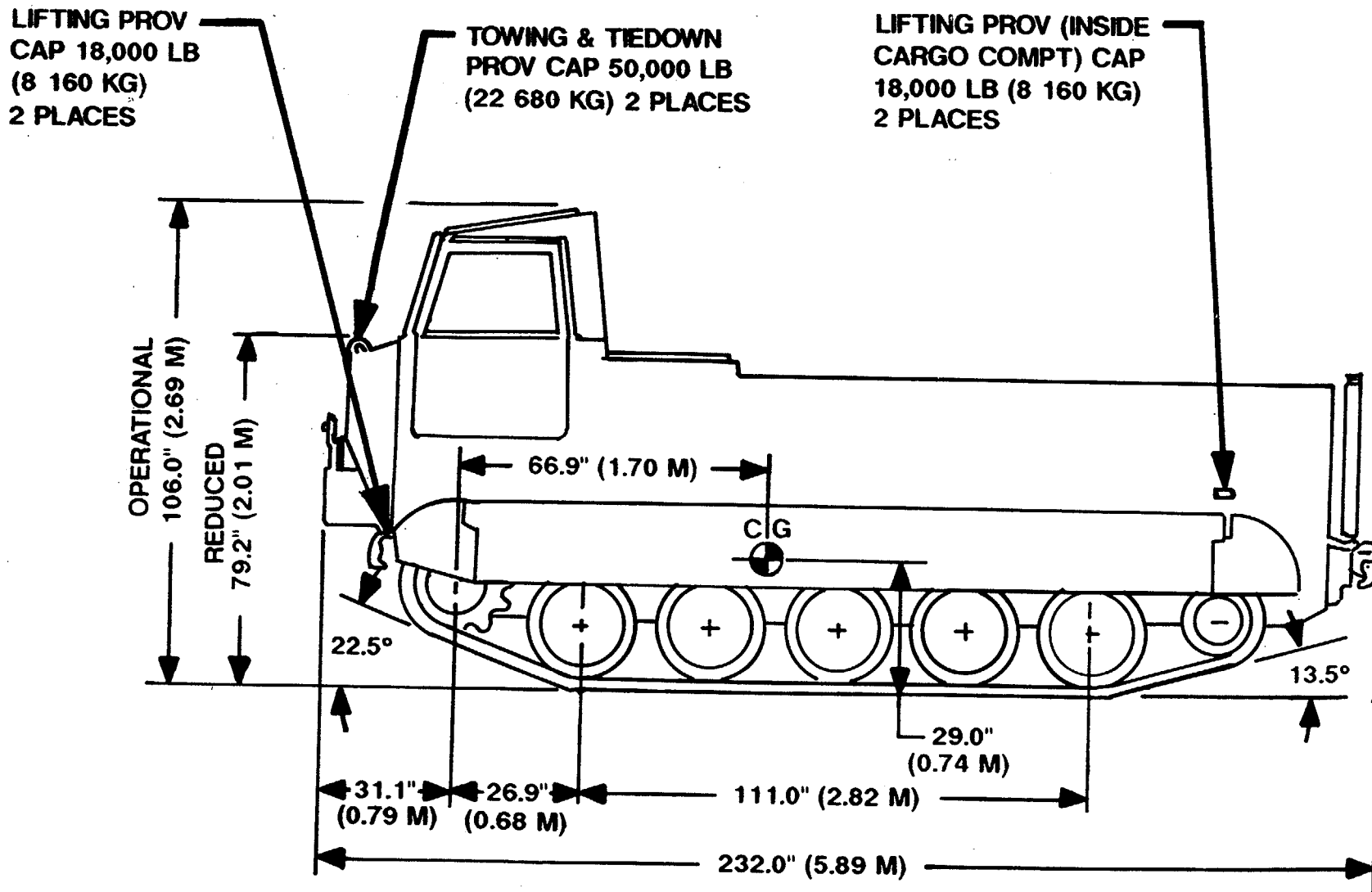

Figure 2-3. Transport configuration of the M1015 tracked cargo carrier.

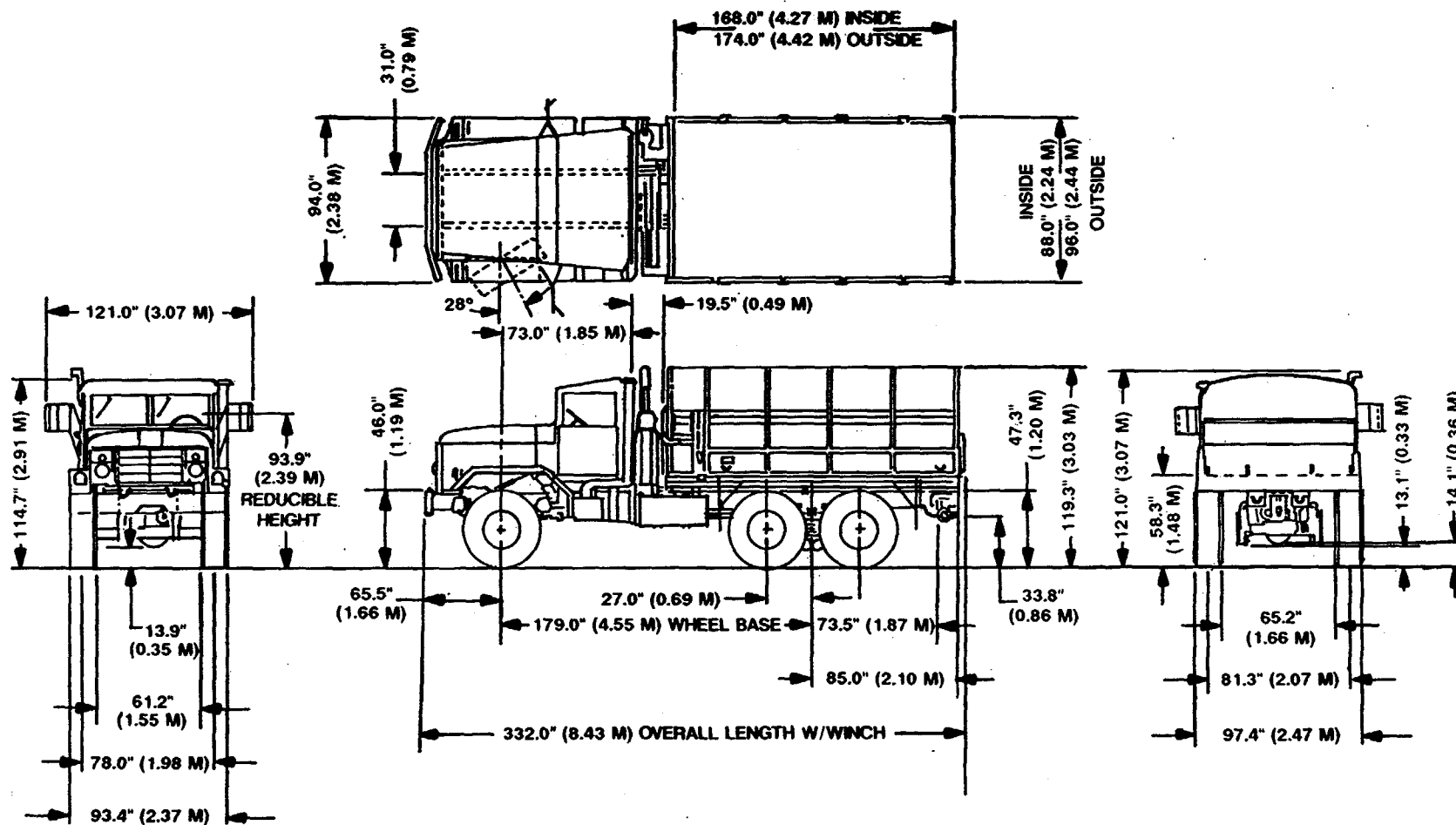

Figure 2-4. Transport configuration of the M925A1 5-ton truck.

ITEM	LENGTH IN. (M)	WIDTH IN. (M)	HEIGHT IN. (M)	VOLUME FT ³ (M ³)	WEIGHT LB (KG)
MAST ASSY	149 (3.78)	34 (0.86)	27 (0.69)	79 (2.24)	1,400 (635.6)
SHELTER ASSY	83 (2.11)	86 (2.18)	75 (1.91)	310 (8.78)	2,570 (1166.8)
GENERATOR	62 (1.57)	32 (0.81)	37 (0.94)	43 (1.22)	1,330 (603.8)
VEHICLE	245 (6.22)	106 (2.69)	106 (2.69)	1,590 (45.02)	17,864 (8110.3)
STAND (APPROX)	91 (2.31)	36 (0.91)	32 (0.81)	40 (1.13)	1,750 (794.5)
TOTAL SYSTEM	245 (6.22)	106 (2.69)	141 (3.58)	2,119 (60.0)	24,914 (11311.0)

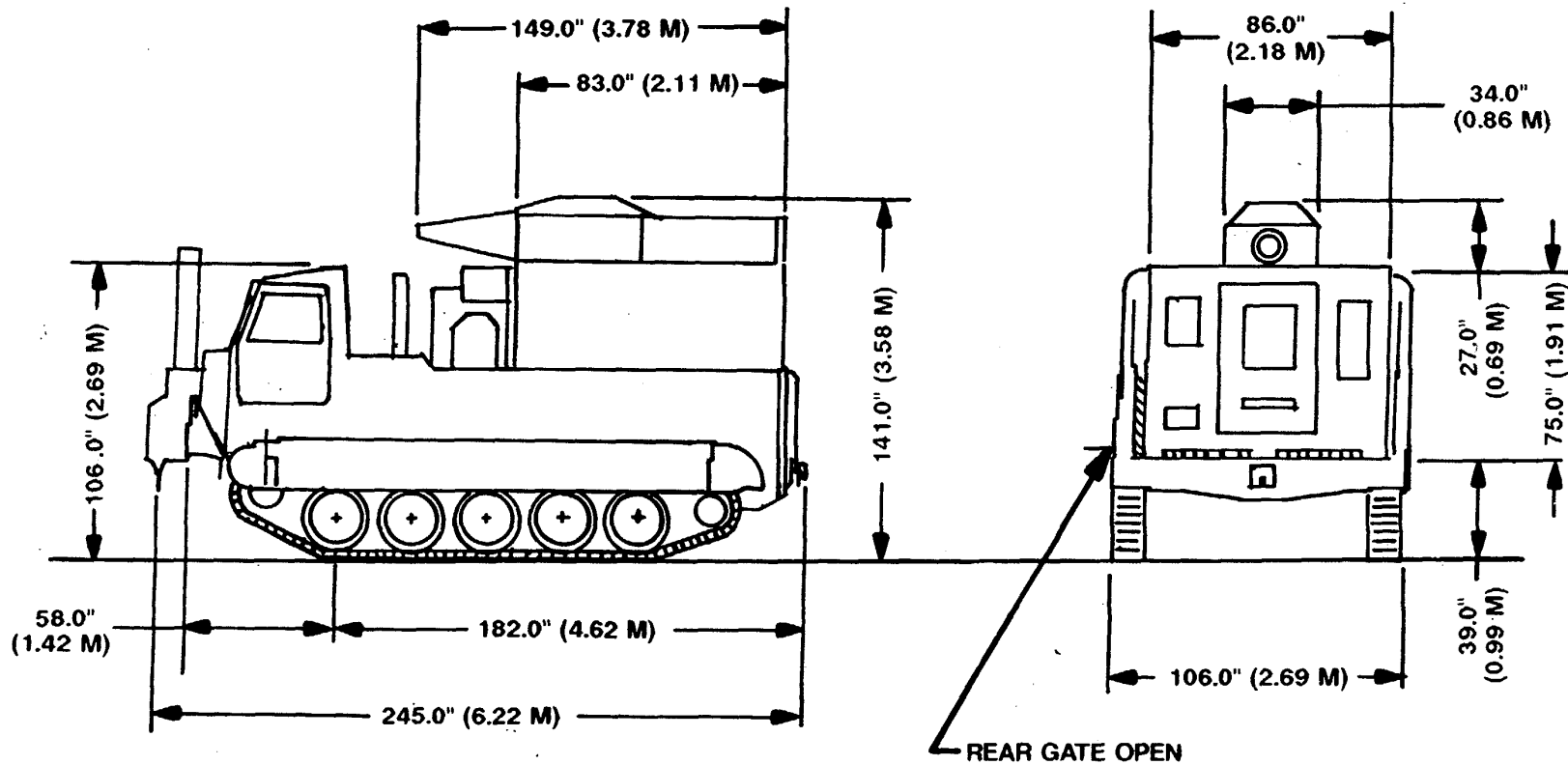

Figure 2-5. TEAMPACK AN/MSQ-103A shelter mounted on the M1015 carrier.

ITEM	LENGTH IN. (M)	WIDTH IN. (M)	HEIGHT IN. (M)	VOLUME FT ³ (M ³)	WEIGHT LB (KG)
MAST ASSY	149 (3.78)	34 (0.86)	27 (0.69)	79 (2.24)	1,400 (635.6)
SHELTER ASSY	83 (2.11)	86 (2.18)	81 (2.06)	310 (8.78)	2,570 (1166.8)
GENERATOR	62 (1.57)	32 (0.81)	37 (0.94)	43 (1.22)	1,330 (603.8)
VEHICLE	245 (6.22)	106 (2.69)	106 (2.69)	1,590 (45.02)	17,864 (8110.3)
SKID	124 (3.15)	91 (2.32)	32 (0.81)	209 (5.92)	1830 (830.82)
TOTAL SYSTEM	245 (6.22)	106 (2.69)	147 (3.73)	2209 (62.55)	24994 (11347.3)

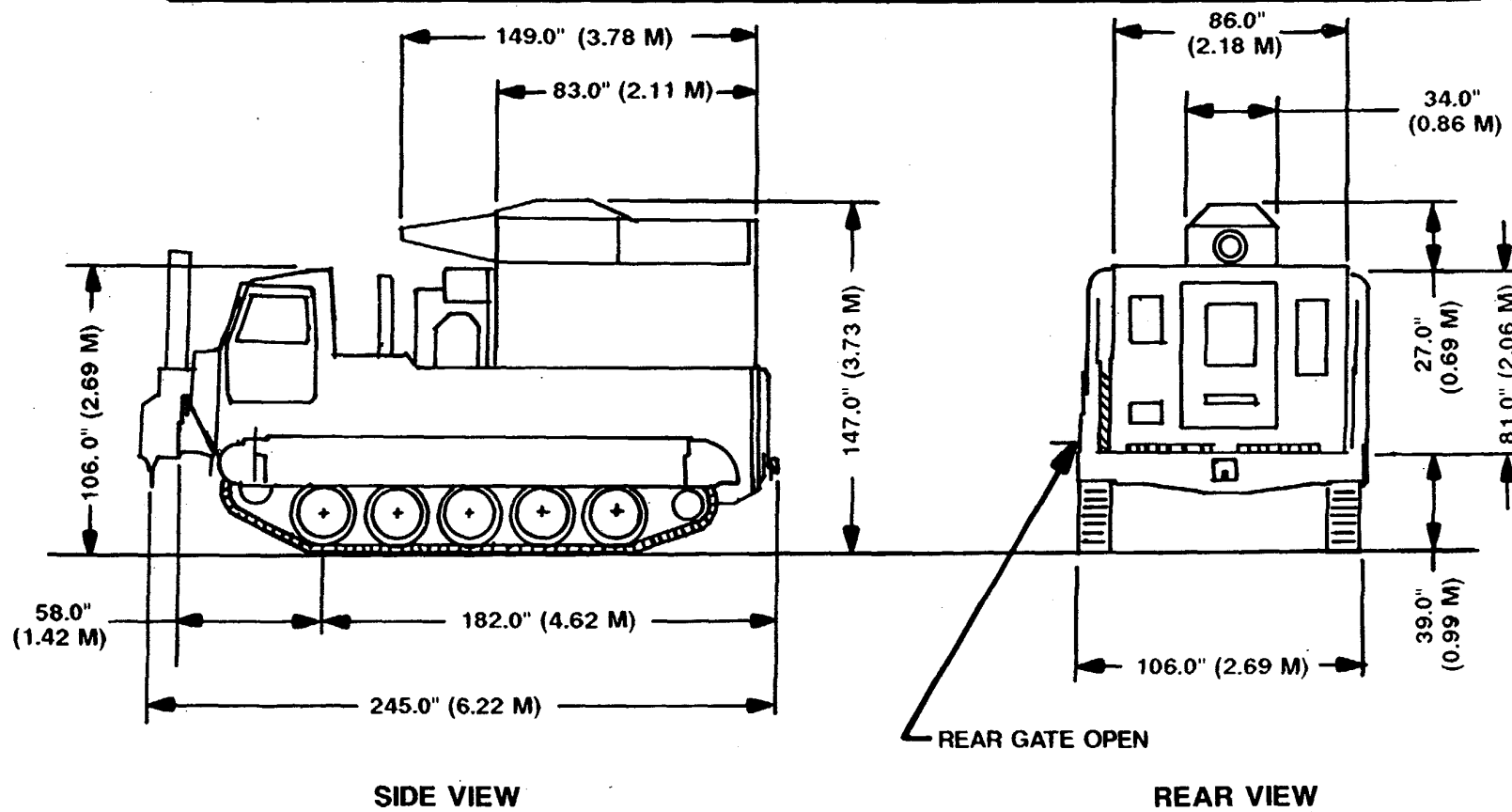

Figure 2-6. TEAMPACK AN/MSQ-103C shelter mounted on the M1015 carrier.

CONFIGURATION	OVERALL LENGTH IN. (M)	OVERALL HEIGHT IN. (M)	OVERALL WIDTH IN. (M)	GROSS WEIGHT LB (KG)
AN/MSQ-103B LIGHTWEIGHT TEAMPACK SHELTER	105.38 (2.68)	68 (1.73)	81.5 (2.07)	2682 (1219)

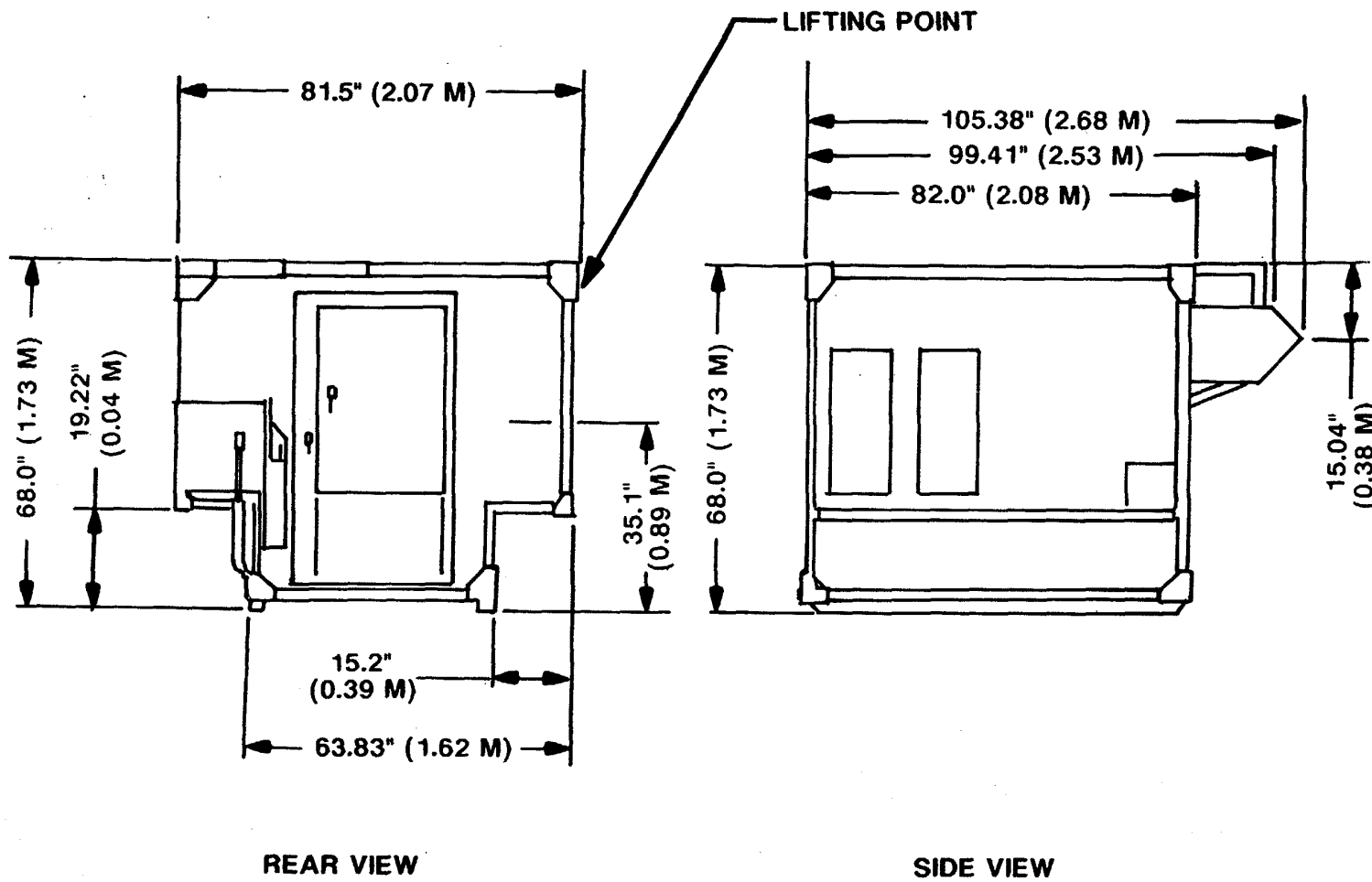

Figure 2-7. AN/MSQ-103B lightweight TEAMPACK shelter.

CONFIGURATION	OVERALL LENGTH IN (M)	OVERALL HEIGHT IN (M)	OVERALL WIDTH IN (M)	FRONT AXLE LOAD LB (KG)	REAR AXLE LOAD LB (KG)	SYSTEM CURB WEIGHT LB (KG)
M1028 CUCV/AN MSQ-103B LIGHTWEIGHT TEAMPACK COMBINATION LESS CREW	220.7 (5.61)	102.0 (2.59)	86.0 (2.18)	3,680 (1671)	4,980 (2261)	8,660 (3932)

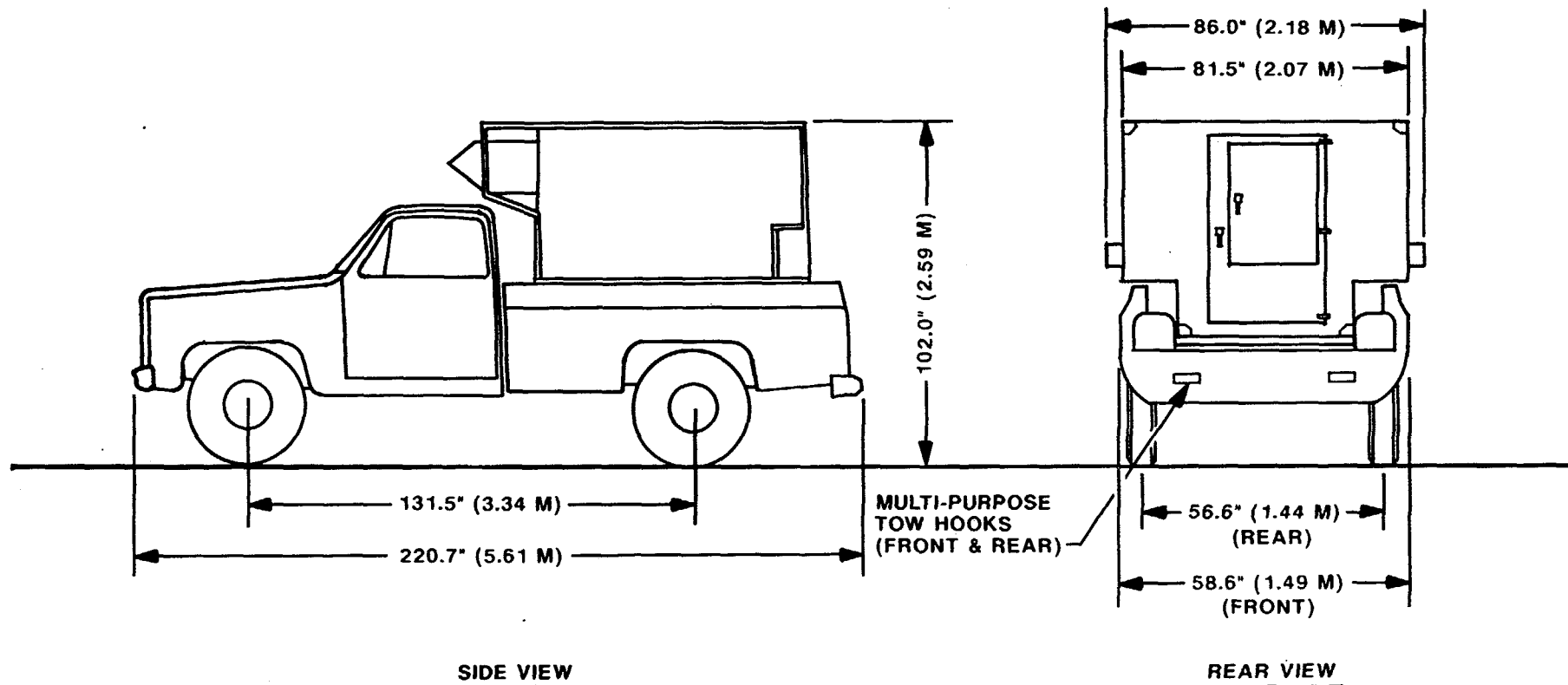

Figure 2-8. AN/MSQ-103B lightweight TEAMPACK shelter mounted in the M1028 CUCV.

CHAPTER 3 SAFETY

3-1. General

General safety precautions for movement are as follows:

- a. Check each vehicle to ensure that all loose items are appropriately secured.
- b. When backing a vehicle, ensure that no personnel or obstructions are behind it.
- c. Do not walk under any items while they are being lifted by crane or other means.
- d. Ensure that fire extinguishers (other than system's extinguishers) are readily available during all loading and offloading procedures.
- e. Do not leave vehicles unattended while engine is running.

f. If track is thrown while carrier is being operated, do not apply brakes unless absolutely necessary. Allow carrier to coast to a stop.

g. Ensure that ventilation is adequate while vehicle engine is running (carbon monoxide poisoning can be deadly).

3-2. Specific Safety Requirements

Pertinent safety requirements by individual mode can be found, where applicable, in the appropriate chapters.

CHAPTER 4 AIR TRANSPORTABILITY GUIDANCE

Section I. GENERAL

4-1. Scope

This chapter provides air transportability guidance for the movement of the TEAMPACK system. It also presents tiedown diagrams and tiedown data for loading this system into C-130, C-141, and C-5 Air Force aircraft.

4-2. Maximum Utilization of Aircraft

Additional cargo and/or personnel, within allowable load limits and restrictions as prescribed by pertinent safety regulations, can be transported with the TEAMPACK in US Air Force aircraft.

4-3. Safety

In addition to the safety precautions contained in chapter 3, the following procedures apply:

a. The activity offering the vehicle or systems for air transport will notify the aircraft commander or his representative when ammunition or explosives are to be transported within a system.

b. In accordance with TM 38-250/AFR 71-4, the fuel level may be three-quarters full when loaded on the cargo floor, or no more than one-quarter full during routine airlift.

c. The vehicles and shelter must be restrained for air transport in accordance with applicable procedures in Air Force Technical Order (TO) IC-XXX 9.

WARNING

Fire extinguishers must be readily available during all loading and unloading operations.

WARNING

Proper ventilation must be provided when loading and unloading. Prolonged inhalation of carbon monoxide fumes may be fatal.

CAUTION

Do not allow vehicles to exceed 3 miles per hour (walking speed) on the loading ramps or inside the aircraft.

CAUTION

The CUCV cannot be externally lifted by helicopter.

NOTE

The CUCV with shelter must be loaded aboard the C-130 and C-141 aircraft forward end first. Do not attempt to load by backing aboard aircraft.

4-4. Responsibility

The loadmaster will ensure that the loaded equipment is secured in accordance with restraint criteria outlined in TO IC-XXX-9.

Section II. TRANSPORT BY US AIR FORCE AIRCRAFT

4-5. Transportability

a. *AN/MSQ-103A/C TEAMPACK System.* The AN/MSQ-103A and -103C TEAMPACK systems are transportable in the C-130, C-141, and C-5 aircraft. The procedures below will be used for loading the TEAMPACK system on the following aircraft.

(2) *C130 and C-141 Aircraft.* The shelter must be removed from the M1015 tracked carrier prior to loading. When the M1015 carrier is loaded, metal parts of the carrier tracks must not make contact with the aircraft loading ramp or cargo compartment floor. The use of shoring is always required when loading and unloading the carrier. Two-by-twelve-inch lumber must be used to provide two rows of shoring 24 inches wide and spaced to match the carrier tracks. Loaded height of carrier may be reduced slightly by use of 3/4 or 1/2-

inch plywood shoring instead of 2x 12-inch lumber. Shoring must be laid from the ground end of the aircraft ramp extension into the cargo compartment so that, when the carrier is in the tiedown position, the tracks are on the shoring. Shoring is provided by the transporting unit or activity. The antenna must be removed from the shelter to meet the 102 and 103-inch clearance requirement of the C-130 and C-141 aircraft, respectively. The shelter must be placed on two interlocked 463L Air Force pallets for shipment.

(2) *C5 Aircraft.* The TEAMPACK system can be transported in the operational configuration. The requirement for shoring is the same as for the C-130 and C-141 aircraft.

NOTE

The M1015 carrier is limited to cross-country and axle weight ratings for airlift. The shelters (S-623) are limited to a gross weight of 6,440 pounds.

NOTE

Procedures for transporting the M925A1 5-ton truck, an alternate mover of the -103A/C TEAMPACK shelters, are explained in TM 55-2320-272-14-1.

b. AN/MSQ-103B Lightweight TEAMPACK. The AN/MSQ-103B lightweight TEAMPACK mounted on the M1028 CUCV can be transported on the C-130, C-141, and C-5 US Air Force aircraft in its operational configuration.

NOTE

The M1028 with shelter mounted must be loaded aboard the C-130 and C-141 aircraft forward end first. Do not attempt to load by backing aboard.

4-6. Tiedown Data

The following tiedown diagrams (figs 4-1 through 4-5) and tiedown data (tables 4-1 through 4-5) provide a guide for securing the TEAMPACK systems aboard US Air Force aircraft. Final tiedown procedures will be at the discretion of the Air Force loadmaster. The figures show a typical tiedown pattern of a representative TEAMPACK for each aircraft. The tables give the capacity of tie-down devices, location points on the vehicles, and aircraft fittings to which the devices are secured.

Table 4-1. Tiedown Data for M1015 Carrier in C-5 Aircraft (Fig 4-1)

<i>Tiedown Fitting</i>		<i>Tiedown Device</i>		
Designation	Capacity in 1,000 lb	Type	Capacity in 1,000 lb	Attach to Item
C11	25	MB-2	25	Left front towing provision.
E11	25	MB-2	25	Right front towing provision.
C12	25	MB-2	25	Left idler wheel arm.
E12	25	MB-2	25	Right idler wheel arm.
C18	25	MB-2	25	No. 5 left road wheel arm.
E18	25	MB-2	25	No. 5 right road wheel arm.
C19	25	MB-2	25	Left rear towing provision.
E19	25	MB-2	25	Right rear towing provision.
D19	25	MB-2	25	Towing pintle.

Table 4-2. Tiedown Data for M1015 Carrier in C-130 and C-141 Aircraft (Fig 4-2)

<i>Tiedown Fitting</i>		<i>Tiedown Device</i>		
Designation	Capacity in 1,000 lb	Type	Capacity in 1,000 lb	Attach to Item
A6	25	MB-2	25	Right rear towing provision.
G6	25	MB-2	25	Left rear towing provision.
A7	25	MB-2	25	Right rear lifting provision.
G7	25	MB-2	25	Left rear lifting provision.
C13	10	MB-1	10	No. 5 right road wheel arm.
E13	10	MB-1	10	No. 5 left road wheel arm.
C15	10	MB-1	10	No. 3 right road wheel arm.
E15	10	MB-1	10	No. 3 left road wheel arm.
C17	10	MB-1	10	No. 2 right road wheel arm.
E17	10	MB-1	10	No. 2 left road wheel arm.
C19	10	MB-1	10	No. 1 right road wheel arm.
E19	10	MB-1	10	No. 1 left road wheel arm.
A21	25	MB-2	25	Right front towing provision.
G21	25	MB-2	25	Left front towing provision.

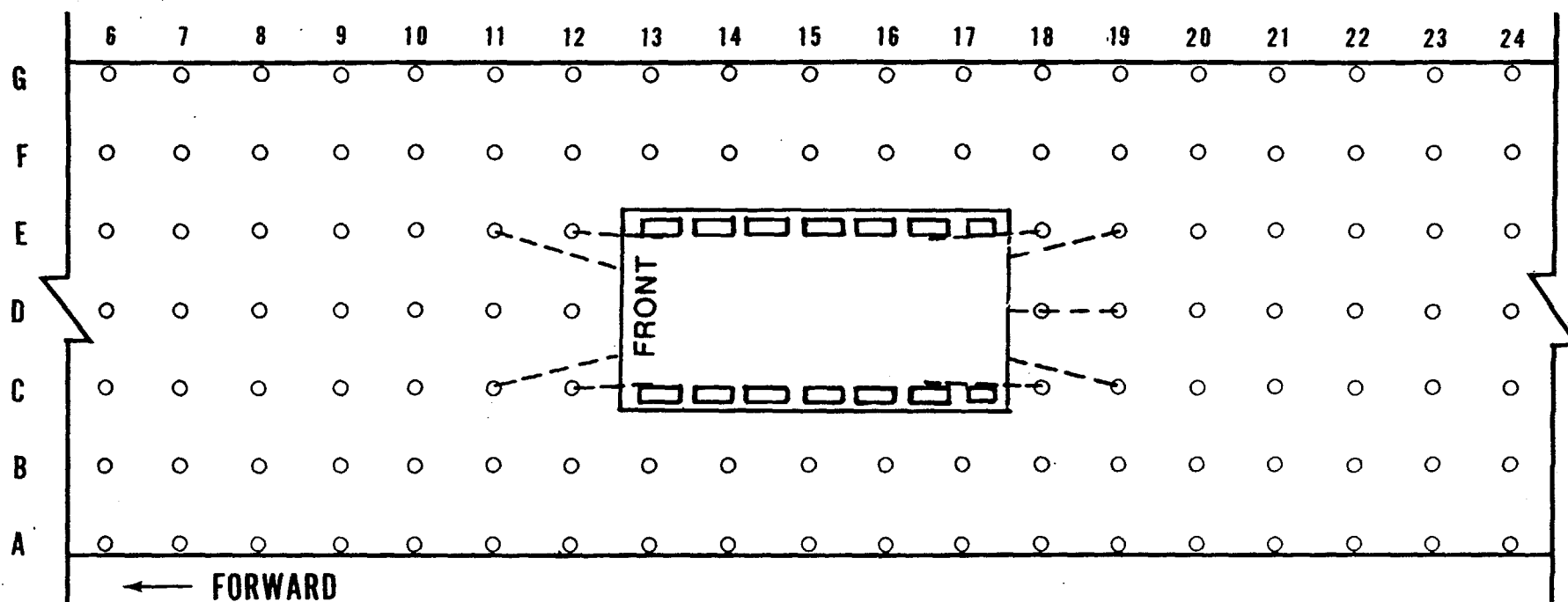

LEGEND: C-5 AIRCRAFT

- ALL CARGO TIEDOWN FITTING RATINGS 25,000 LB EACH

NOTE: FLOOR TIEDOWN FITTINGS ARE LOCATED IN ROWS A THROUGH G AND COLUMNS 1 THROUGH 38. ADDITIONAL COLUMNS OF TIEDOWNS ARE LOCATED ON THE RAMPS: FOUR ON THE FORWARD RAMP AND FIVE ON THE AFT RAMP. THIS IS A TYPICAL TIEDOWN PROCEDURE AND ONLY COLUMNS 6 THROUGH 24 ARE SHOWN. ITEM BEING SHIPPED CAN BE TIED DOWN AT ANY LOCATION APPROVED BY THE LOADMASTER.

Figure 4-1. Tiedown diagram for M1015 carrier in C-5 aircraft.

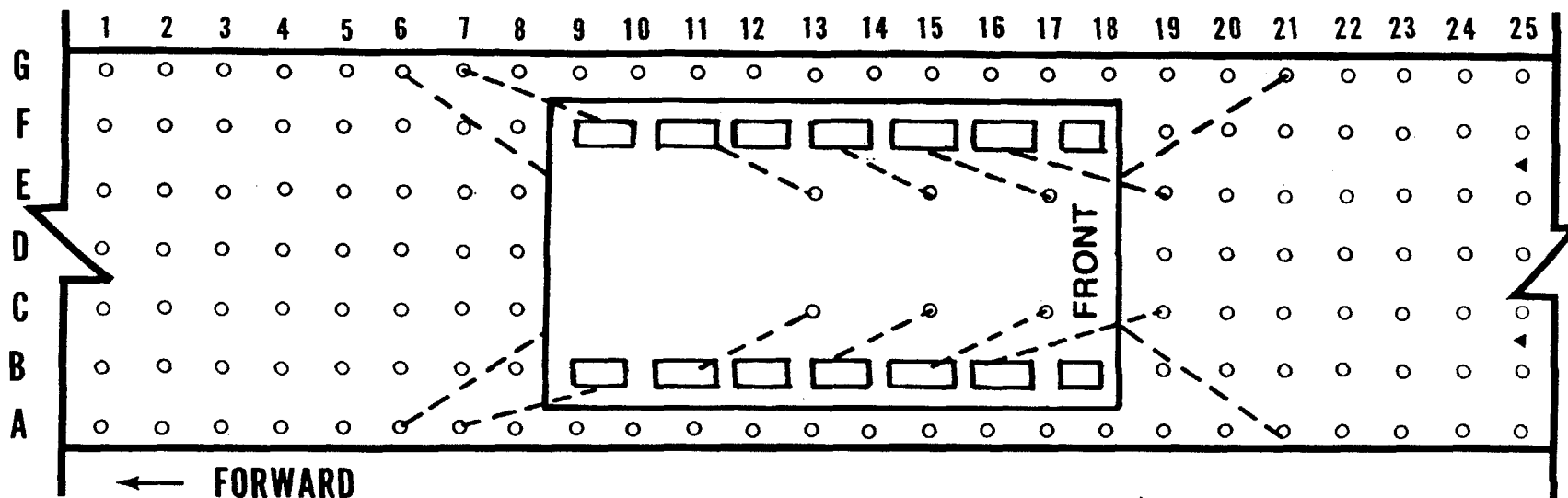

LEGEND: C-130 AND C-141 AIRCRAFT

- 10,000-POUND-CAPACITY TIEDOWN FITTING
- ▲ 25,000-POUND-CAPACITY TIEDOWN FITTING

NOTE: FLOOR TIEDOWN FITTINGS ARE LOCATED IN ROWS A THROUGH G AND COLUMNS 1 THROUGH 25. THE RAMP HAS 5 ADDITIONAL COLUMNS. THIS IS A TYPICAL TIEDOWN PROCEDURE AND ONLY COLUMNS 1 THROUGH 25 ARE SHOWN. ITEM BEING SHIPPED CAN BE TIED DOWN AT ANY LOCATION APPROVED BY THE LOADMASTER.

Figure 4-2. Tiedown diagram for M1015 carrier in C-130 and C141 aircraft.

Table 4-3. Tiedown Data for TEAMPACK Shelters Secured to Two Interlocked 463L Pallets (HUC 61E) (Fig 4-3)

Tiedown Fitting		Tiedown Device		
Designation	Capacity in 1,000 lb	Type	Capacity in 1,000 lb	Attach to Item
3	7.5	MB-1	10	Forward right top tiedown.
4	7.5	MB-1	10	Forward left top tiedown.
9	7.5	MB-1	10	Forward right bottom tiedown.
10	7.5	MB-1	10	Forward right bottom tiedown.
11	7.5	MB-1	10	Aft right top tiedown.
12	7.5	MB-1	10	Forward right top tiedown.
14	7.5	MB-1	10	Aft right bottom tiedown.
18	7.5	MB-1	10	Aft right top tiedown.
19	7.5	MB-1	10	Aft right bottom tiedown.
20	7.5	MB-1	10	Aft left bottom tiedown.
21	7.5	MB-1	10	Aft left top tiedown.
25	7.5	MB-1	10	Aft left bottom tiedown.
27	7.5	MB-1	10	Forward left top tiedown.
28	7.5	MB-1	10	Aft left top tiedown.
29	7.5	MB-1	10	Forward left bottom tiedown.
30	7.5	MB-1	10	Forward left bottom tiedown.

Table 4-4. Tiedown Data for CUCV in USAF C-130 and C-141 Aircraft (Fig 4-4)

Tiedown Fitting		Tiedown Device		
Designation	Capacity in 1,000 lb	Type	Capacity in 1,000 lb	Attach to Item
B15	10	MB-1	10	Right rear bumper tiedown fitting.
D15	10	MB-1	10	Right rear bumper tiedown fitting.
D15	10	MB-1	10	Left rear bumper tiedown fitting.
F15	10	MB-1	10	Left rear bumper tiedown fitting.
D31	10	MB-1	10	Right front bumper tiedown fitting.
D31	10	MB-1	10	Left front bumper tiedown fitting.
A33	10	MB-1	10	Right front bumper tiedown fitting.
G33	10	MB-1	10	Left front bumper tiedown fitting.

Table 4-5. Tiedown Data for CUCV in USAF C-5 Aircraft (Fig 4-5)

Tiedown Fitting		Tiedown Device		
Designation	Capacity in 1,000 lb	Type	Capacity in 1,000 lb	Attach to Item
G11	25	MB-1	25	Left front bumper tiedown fitting (veh 1).
F11	25	MB-1	25	Left front bumper tiedown fitting (veh 1).
F11	25	MB-1	25	Right front bumper tiedown fitting (veh 1).
E11	25	MB-1	25	Right front bumper tiedown fitting (veh 1).
C11	25	MB-1	25	Left front bumper tiedown fitting (veh 2).
B11	25	MB-1	25	Left front bumper tiedown fitting (veh 2).
B11	25	MB-1	25	Right front bumper tiedown fitting (veh 2).
A11	25	MB-1	25	Right front bumper tiedown fitting (veh 1).
G18	25	MB-2	25	Left rear bumper tiedown fitting (veh 1).
F18	25	MB-2	25	Left rear bumper tiedown fitting (veh 1).
F18	25	MB-2	25	Right rear bumper tiedown fitting (veh 1).
E18	25	MB-2	25	Right rear bumper tiedown fitting (veh 1).
C18	25	MB-2	25	Left rear bumper tiedown fitting (veh 2).
B18	25	MB-2	25	Left rear bumper tiedown fitting (veh 2).
B18	25	MB-2	25	Right rear bumper tiedown fitting (veh 2).
A18	25	MB-2	25	Right rear bumper tiedown fitting (veh 2).

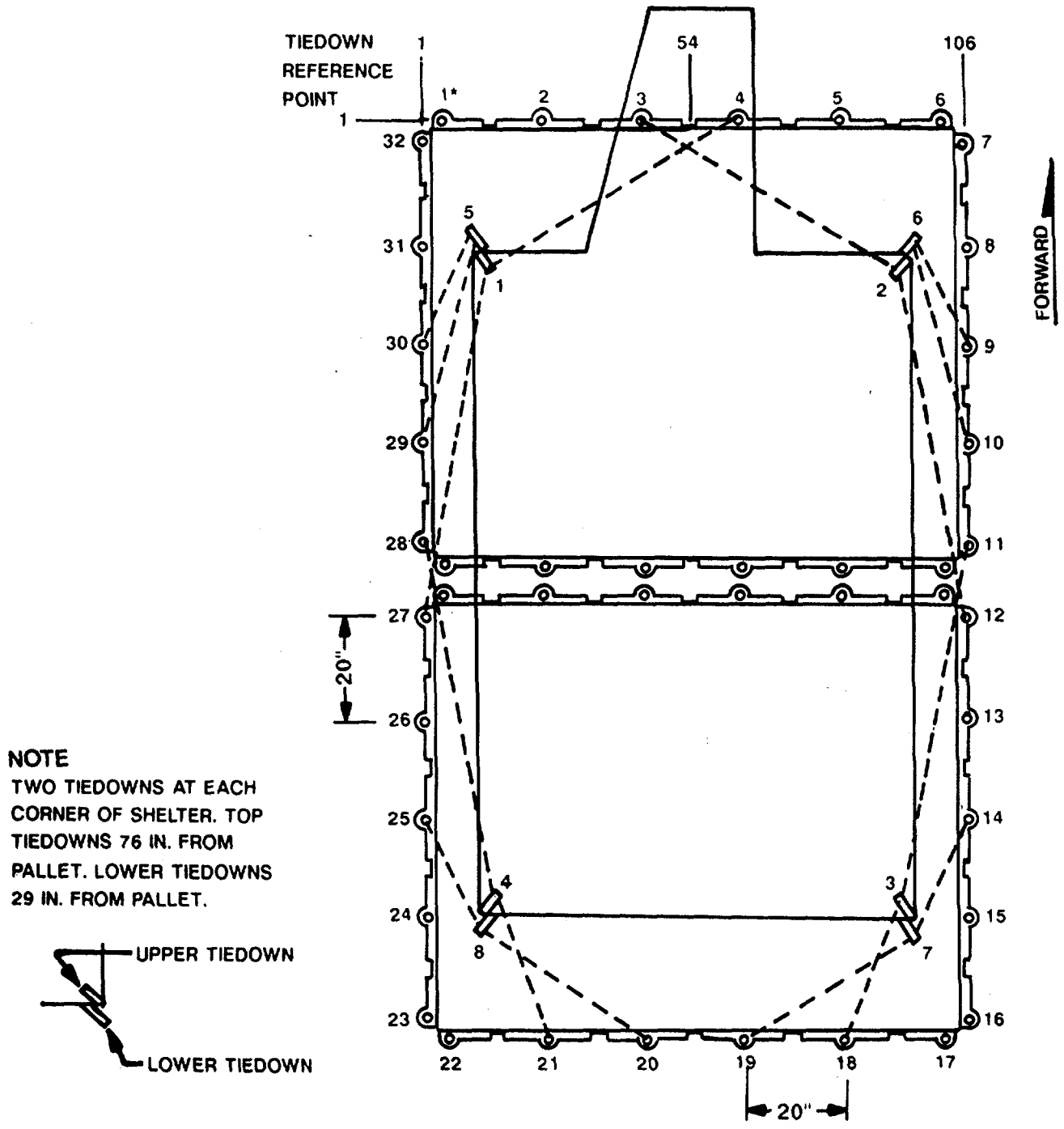

* 7,500-POUND-CAPACITY TIEDOWN RINGS

Figure 4-3. Tiedown diagram for shelters on two interlocked 463L pallets.

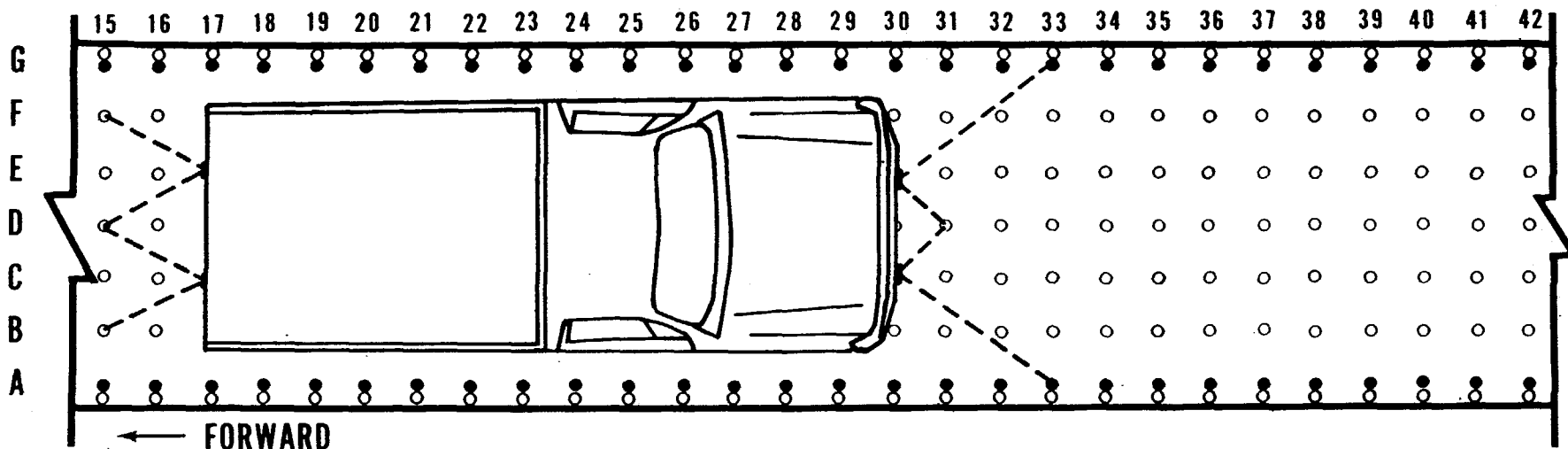

LEGEND: C-130 AND C-141 AIRCRAFT

- 10,000-POUND-CAPACITY TIEDOWN FITTING
- 25,000-POUND-CAPACITY TIEDOWN FITTING

NOTE: FLOOR TIEDOWN FITTINGS ARE LOCATED IN ROWS A THROUGH G AND COLUMNS 1 THROUGH 56. THE RAMP HAS 6 ADDITIONAL COLUMNS. THIS IS A TYPICAL TIEDOWN PROCEDURE AND ONLY COLUMNS 15 THROUGH 42 ARE SHOWN. ITEM BEING SHIPPED CAN BE TIED DOWN AT ANY LOCATION APPROVED BY THE LOADMASTER.

Figure 4-4. Tiedown diagram of CUCV in C130 and C141 aircraft.

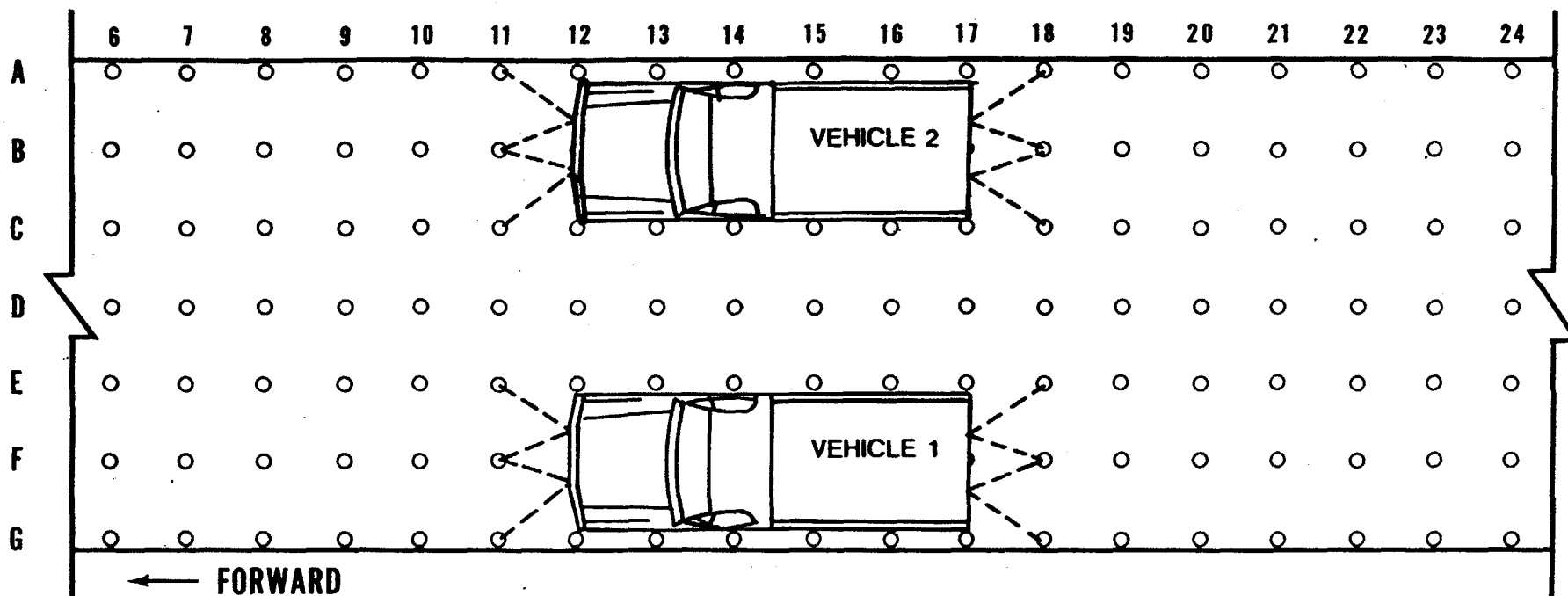

LEGEND: C-5 AIRCRAFT

- ALL CARGO TIEDOWN FITTING RATINGS 25,000 LB EACH

NOTE: TIEDOWN FITTINGS ARE LOCATED IN ROWS A THROUGH G AND COLUMNS 1 THROUGH 48. TEN OF THESE ARE LOCATED ON THE RAMPS : FIVE ON THE FORWARD RAMP AND FIVE ON THE AFT RAMP. THIS IS A TYPICAL TIEDOWN PROCEDURE AND ONLY COLUMNS 6 THROUGH 24 ARE SHOWN. ITEM BEING SHIPPED CAN BE TIED DOWN AT ANY LOCATION (1-42) APPROVED BY THE LOADMASTER.

Figure 4-5. Tiedown diagram of CUCV in C-5 aircraft

CHAPTER 5 HIGHWAY TRANSPORTABILITY GUIDANCE

Section I. GENERAL

5-1. Scope

This chapter provides onroad and offroad transportability guidance for the AN/MSQ-103A/B/C TEAMPACK systems. It covers significant technical and physical characteristics and safety precautions. It also prescribes the materials and provides the guidance required to prepare, load, tie down, and unload these systems.

5-2. Safety

In addition to the safety precautions contained in chapter 3, movement of the systems within CONUS is subject to all safety laws, rules, and regulations applicable to commercial carriers. Overseas movements are governed by theater and local regulations.

5-3. Self-Propelled Movement

a. The AN/MSQ-103A/C/M1015 carrier is self-deliverable only under appropriate tactical situations. Although the carrier tracks are equipped with rubber pads, movement over paved public highways will not be made without specific approval from the Federal, State, and/or local authorities prior to movement.

b. The AN/MSQ-103A/C shelters mounted on the M925A1 can move over paved highways with minor restrictions. Permits will be required for transport in these areas.

c. The AN/MSQ-103B/M1028 CUCV can move without any restrictions over all road networks within CONUS and overseas. No special preparation is required for the vehicle to move under its own power.

5-4. Transport by Semitrailers

a. The -103A/C/M1015 can be transported by military or commercial lowbed semitrailers of adequate

capacity. The -103A/C/NM1015 loaded on semitrailers will cause restrictions throughout the United States and in many foreign countries. The overall width and height exceed legal limits in all the United States and in most foreign countries. It will be necessary to remove the antenna from the shelters in order to meet the United States permit limits and reduce foreign highway restrictions. In special cases, it may be necessary to separate the shelters from the M1015 carrier to allow highway transport of the system. The overall length of the truck tractor and semitrailer will exceed the legal limits in many foreign countries. Permits will be required prior to highway movement in both the United States and foreign countries.

b. The -103B/M1028 CUCV may be transported over highway by both military and commercial flatbed semitrailers. Semitrailers not more than 96 inches wide will provide for unrestricted moves in CONUS and foreign countries. Special preparation of the -103B/M1028 CUCV for transport by semitrailer may consist of reducing the system to its lowest shipping configuration. Normally, the overall height of the system, when loaded on the M127A1 semitrailer, will not exceed 13 feet 6 inches.

NOTE

Dimension and weight limits for highway transport throughout the United States are published by the American Trucking Association (ATA), Alexandria, Virginia. Legal limitations for foreign areas are identified in Limits of Motor Vehicle Sizes and Weights, International Road Federation, 1-23 Washington Building, Washington, DC 20005.

Section II. PREPARATION, LOADING, UNLOADING, AND MATERIALS FOR TRANSPORT ON A SEMITRAILER

5-5. Preparation

Secure or remove antennas. Fold all mirrors and secure loose gear with nylon cord or suitable substitute.

5-6. Loading, Unloading, and Materials

a. *Loading the -103A/C/M1015 System onto a Semitrailer.*

(1) The -103A/C/M1015 system may be driven onto the semitrailer if a suitable ramp is available. It may also be placed in the tiedown position on the semitrailer by a crane of adequate capacity.

position, the transmission shall be placed in neutral and wire-tied to prevent movement, and its parking brakes shall be set.

NOTE

The TEAMPACK shelter must be removed from the M1015 chassis during crane lifting operations. Otherwise, a lifting beam and spreader bar will be required for lifting the -103A/C/M1015 system. When the system is in the tiedown

(2) A tiedown diagram that shows how to adequately restrain the load against forces encountered at normal speeds and operating conditions is shown in figure 5-1. Tiedown details are given in tables 5-1 and 5-2. Dimensions of the M172A1 semitrailer and the -103A/C TEAMPACK mounted on the semitrailer are shown in figure 5-2.

Table 5-1. Bill of Materials for Tiedown of TEAMPACK on M172A1 Semitrailer (Fig 5-1)

Item	Description	Approximate Quantity
Shackles	Anchor shackle, screw-pin, type IV, class 1; Fed Spec RR-C-271; 1/2-inch (1-inch-diameter pin); NSN 4030-00-162-9668	4
Wire rope	6 x 19, IWRC; improved plow steel; preformed, regular-lay; table X, Fed Spec RR-W-410: 1/2-inch	60 feet
Clamps	Wire rope, U-bolt clamps, saddled, single-grip, forged steel, Crosby heavy-duty, or equal; Fed Spec FF-C-450: 1/2-inch	24
Thimbles	Standard, open-type: 1/2-inch	8

Table 5-2. Application of Materials for Tiedown of TEAMPACK on M172A1 Semitrailer (Fig 5-1)

Item	No. Required	Application
A	4	Shackles. Attach one shackle to each front and rear towing provision.
B	4	Wire rope, 1/2-inch, 6 x 19 IWRC. Attach wire rope to each shackle on the carrier and to the tiedown provisions on the trailer, to form a complete loop.
C	24	Clamps. Four for each loop.

b. Loading the -103B/M1028 CUCV onto a Semitrailer.

(1) The system may be towed or driven onto a flatbed trailer if ramps are available. The system may also be placed in the tiedown position by a crane. However, the vehicle must be checked to see if the frame reinforcement kit has been applied before the

vehicle can be lifted at the gross vehicle weight.

(2) After the vehicle has been placed in the tiedown position, it will be tied down on the semitrailer as shown in figure 5-3. The bill of materials and application of materials for tiedown of the system are provided in tables 5-3 and 5-4, respectively.

Table 5-3. Bill of Materials for Tiedown of CUCV on Semitrailer (Fig 5-3)

Item	Description	Approximate Quantity
Wire rope	6 x 19, IWRC; improved plow steel; preformed, regular-lay; table X, Fed Spec RR-W-410: 3/8-inch	48 feet
Clamps	Wire rope, U-bolt clamps, saddled, single-grip, forged steel, Crosby heavy-duty, or equal; Fed Spec FF-C-450: 3/8-inch	20
Thimbles	Standard, open-type: 3/8 inch	4

Table 5-4. Application of Materials for Tiedown of CUCV on Semitrailer (Fig 5-3)

Item	No. Required	Application
A	4	Tiedowns. Each consists of one piece of 3/8-inch, 6 x 19, IWRC rope, length as required (about 12 feet). Form a complete loop between tiedown provisions and appropriate semitrailer stake pocket. The angle between the tiedowns and the trailer deck should be as close to 45° as possible. The wire rope should overlap at least 24 inches.
B	4	Thimbles. Place one thimble under wire rope when wire rope contacts bottom of stake pocket. Secure thimble to wire rope with one U-bolt clamp.
C	20	Clamps. Place four on each item A at overlap area. Space clamps 21/2 inches apart, with a minimum of 6 inches from ends of wire rope. Place one on each item B as indicated above.

NOTE

Tension wire rope with a come-along mechanical hoist or equal tensioning device.

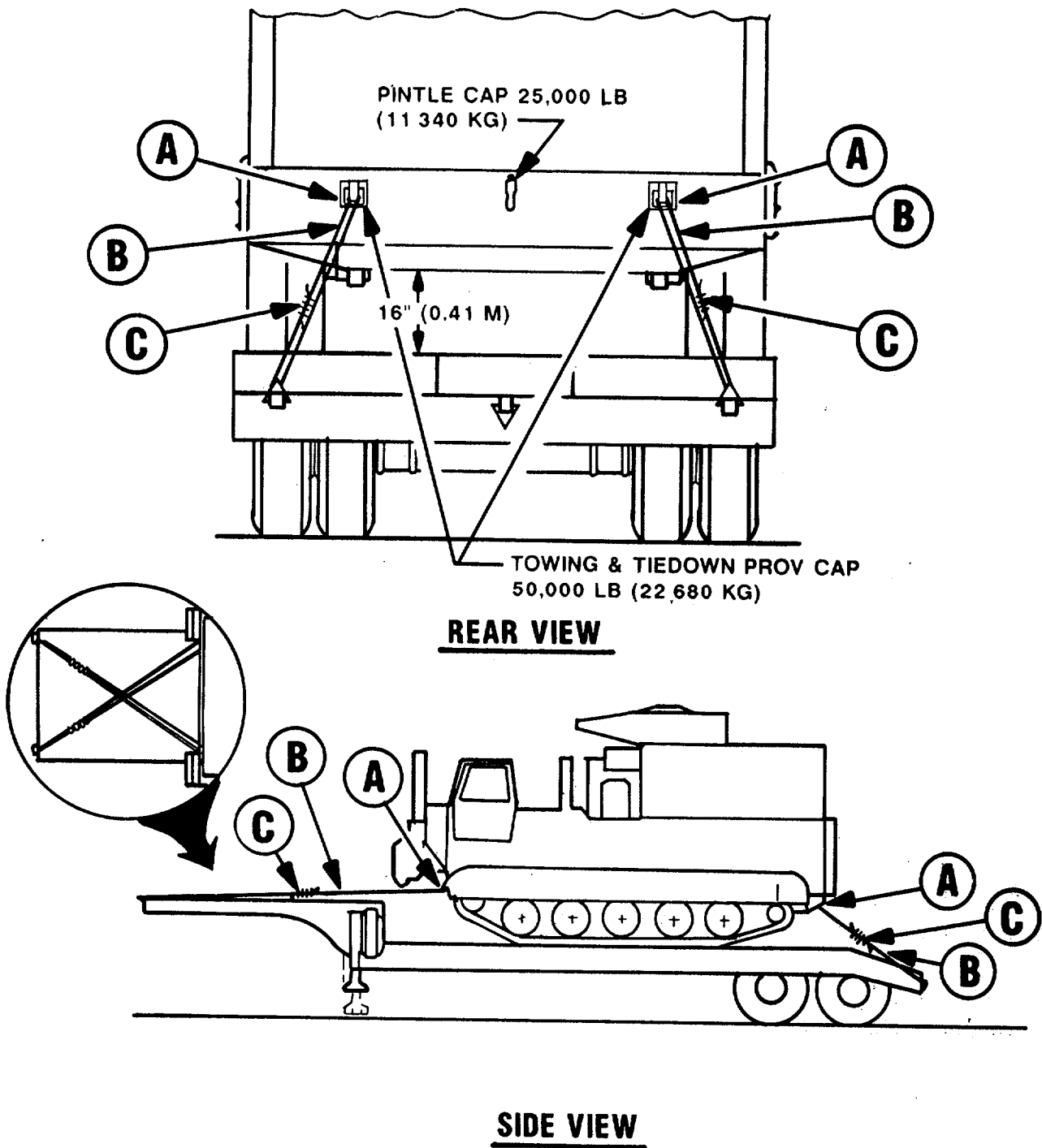
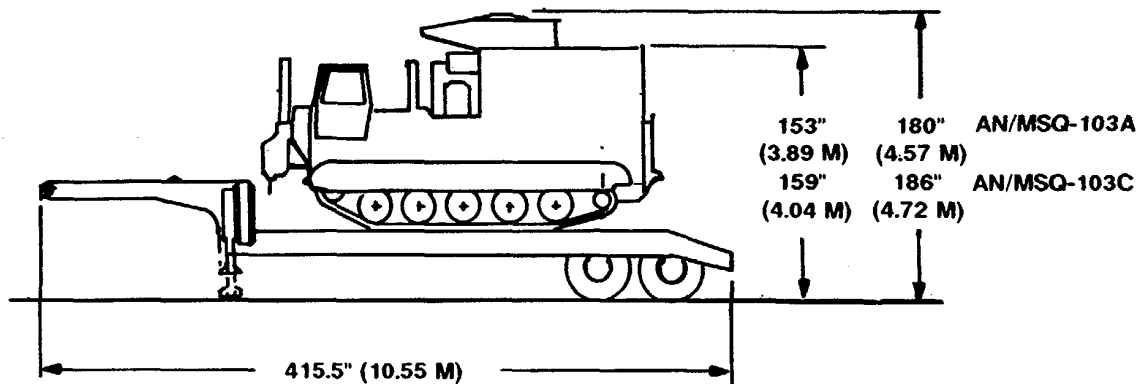

Figure 5-1. Tiedown of the TEAMPACK on the M172A1 semitrailer.



TEAMPACK MOUNTED ON THE M172A1 SEMITRAILER

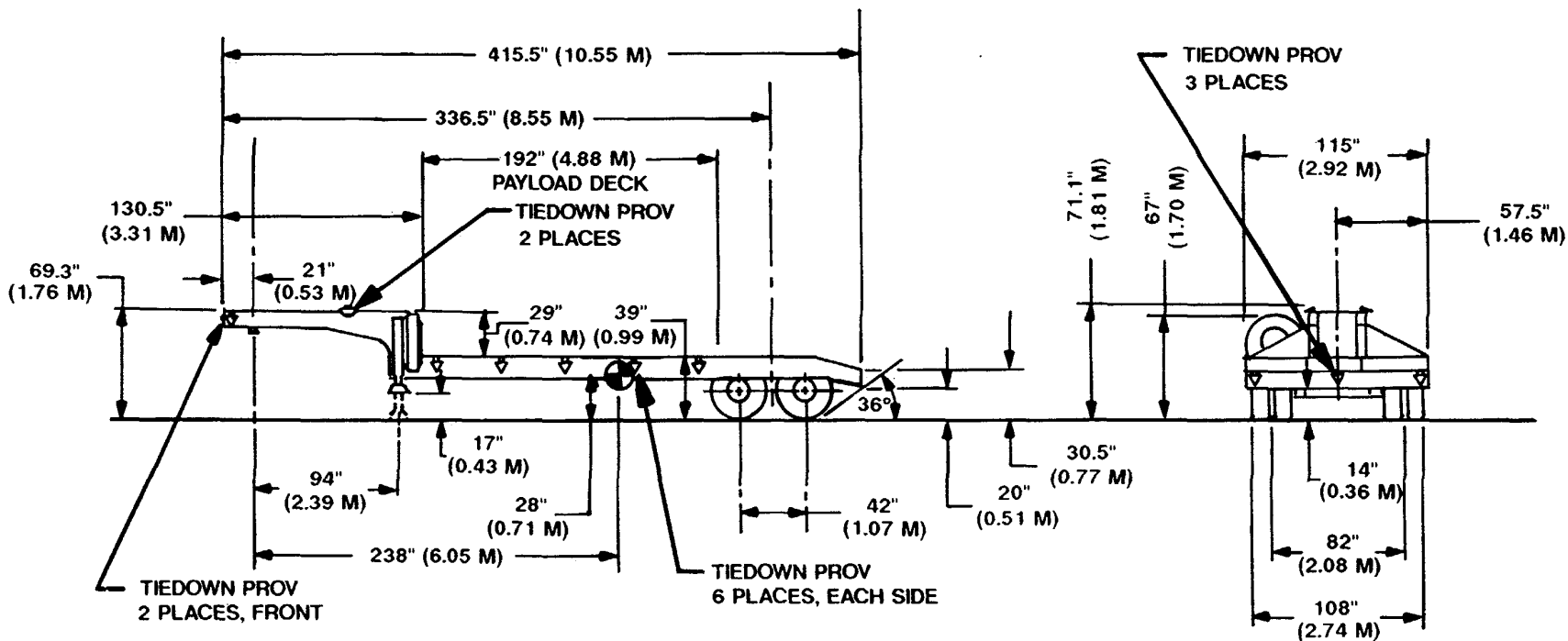

Figure 5-2. Dimensions of the M172A1 semitrailer and the TEAMPACK mounted on the M172A1 semitrailer.

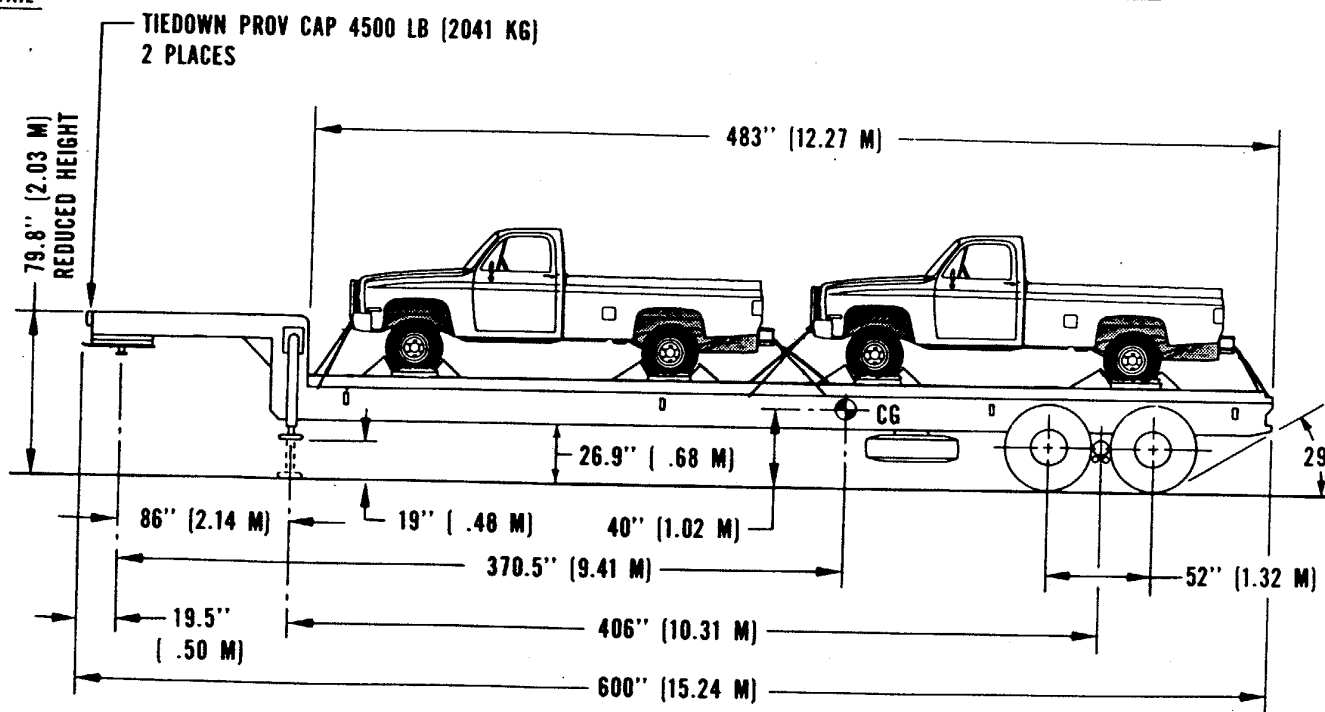
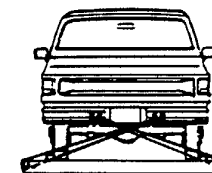
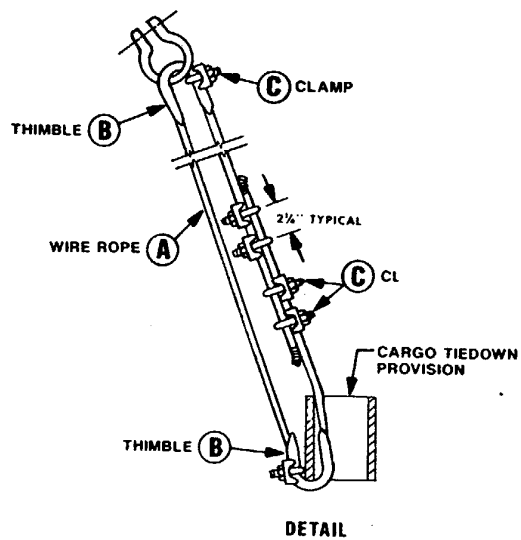

Figure 5-3. Typical tiedown of the CUCV on a semitrailer.

CHAPTER 6 MARINE AND TERMINAL TRANSPORTABILITY GUIDANCE

Section I. GENERAL

6-1. Scope

This chapter provides guidance for transporting the -103A/C TEAMPACK and -103B lightweight TEAMPACK systems by the marine mode. It covers significant technical and physical characteristics and safety precautions. It also prescribes the materials required to prepare, load, tie down, and unload both systems.

6-2. Safety

In addition to the safety precautions contained in chapter 3, the following precautions should be taken as applicable:

- a. Inspect all vessel equipment and gear prior to use.
- b. Inspect all slings and other items used in loading and offloading operations for safe condition and adequate capacity.
- c. Inspect lifting rings and shackles on each piece of equipment to ensure they are complete and not damaged.

- d. Ensure all lifts have at least two taglines attached to control the swing of each item while suspended.

NOTE

When vehicles are loaded onto vessels that are adequately ventilated by power blowers, such as roll-on/roll-off (RORO) vessels, the vehicle's fuel tank does not have to be drained.

NOTE

The methods described in this chapter for lifting and securing items of equipment are suggested procedures. Other methods of handling and stowing may be used provided they ensure safe delivery without damage.

Section II. LOADING AND SECURING

6-3. Transportability

- a. The TEAMPACK/M1015 and the TEAMPACK/M925A1 combinations can be transported on the LACV-30 and larger vessels.
- b. The lightweight TEAMPACK/M1028 combination is transportable by all vessels.

6-4. General Rules for Stowage

Whenever possible, the vehicles should receive the protection of below-deck storage on cargo ships and RORO vessels. Good stowage is accomplished by placing vehicles fore and aft as close together as practical, with 4 to 6-inch spacing between outer vehicles and sweatboards. If not shipped on the vehicle, breakable parts, spare parts, and OEM (on-equipment materiel) should be protected and properly identified as to location or disposition during shipment. Vehicles in the ship's hold should have wheels blocked in front, in rear, and on both sides so that vehicles cannot move in any direction. Individual wheel blocks should be braced to bulkheads, stanchions, and other wheel blocks. All vehicles should be lashed with wire ropes or chains to nearby bulkheads, stanchions, or padeyes.

a. Lifting.

(1) TEAMPACK/M1015 and M925A1. The M1015 carrier has four lifting points: two on the upper front corners and two inside the cargo compartment at the rear. When the TEAMPACK shelter is transported, the rear lifting eyes are not accessible. A lifting beam must be used to lift the M1015 when the shelter is attached. If a lifting beam is not available, lift the TEAMPACK shelter separately from the carrier. The -103A TEAMPACK shelter is lifted using the four lifting provisions on the top corners of the shelter (same procedures used to lift S-280 shelters). The -103C TEAMPACK shelter is lifted using the two aft shelter lifting provisions and the two skid swivels. Figures 6-1 and 6-2 show the procedures for lifting the M1015 with and without the TEAMPACK shelter. Figure 6-3 shows the procedures for lifting the -103C TEAMPACK shelter. Procedures for lifting and securing the M925A1 are published in TM 55-2320-272-14-1. A lifting beam and spreader bar are used to lift the M1015 when the TEAMPACK shelter is attached to the vehicle (fig 6-2). A 9-foot lift beam assembly is required to lift the -103C shelter configuration (fig 6-3).

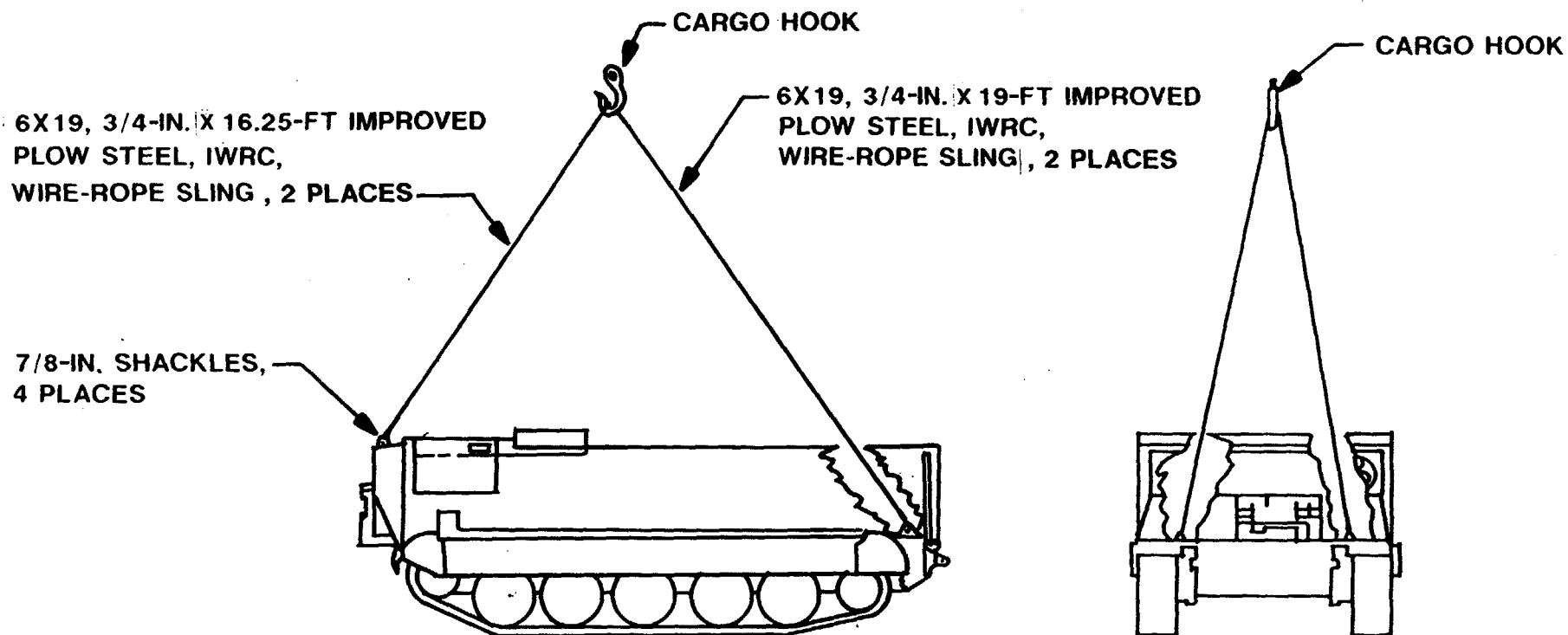

Figure 6-1. Lifting diagram for M1015 carrier without shelter attached

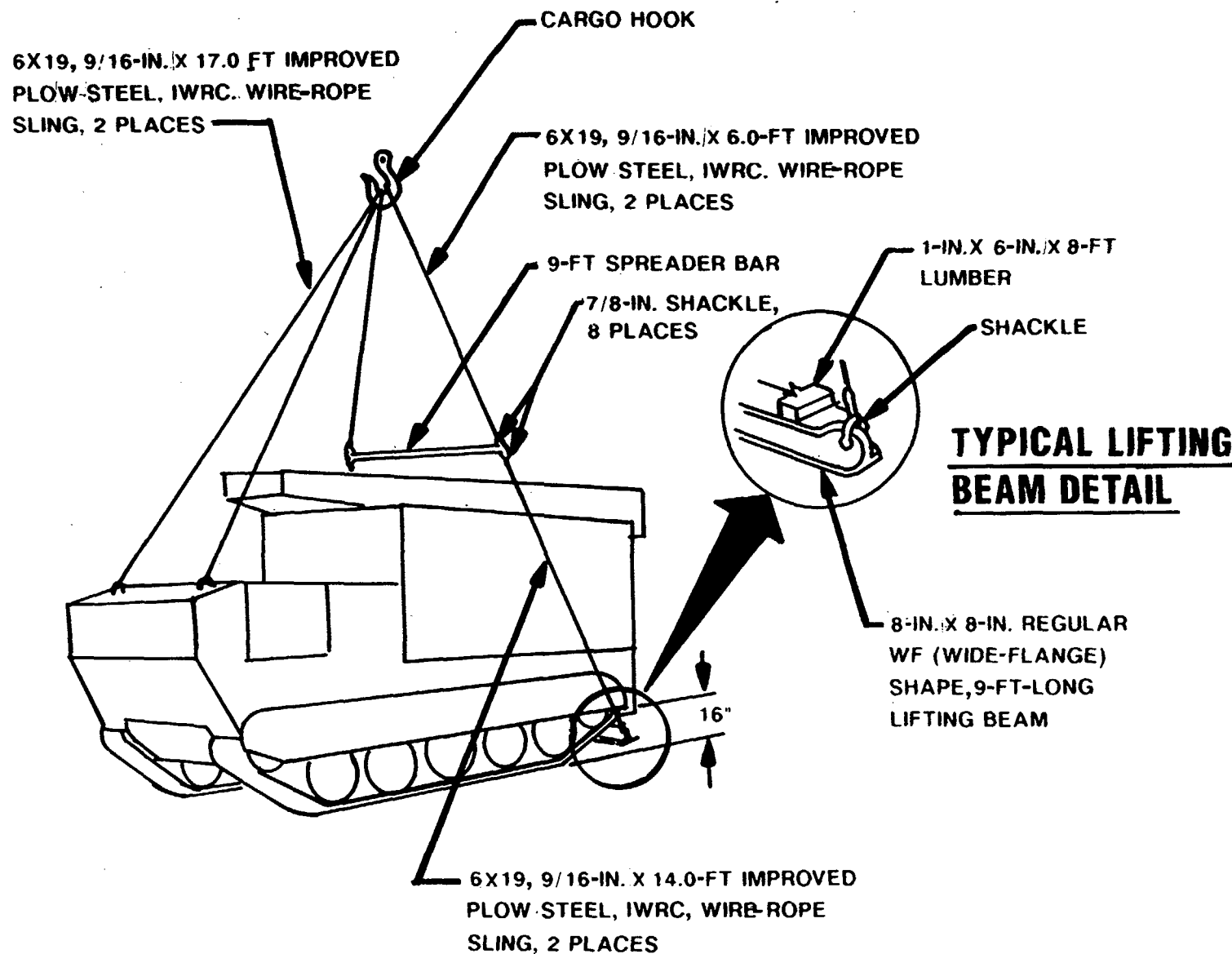
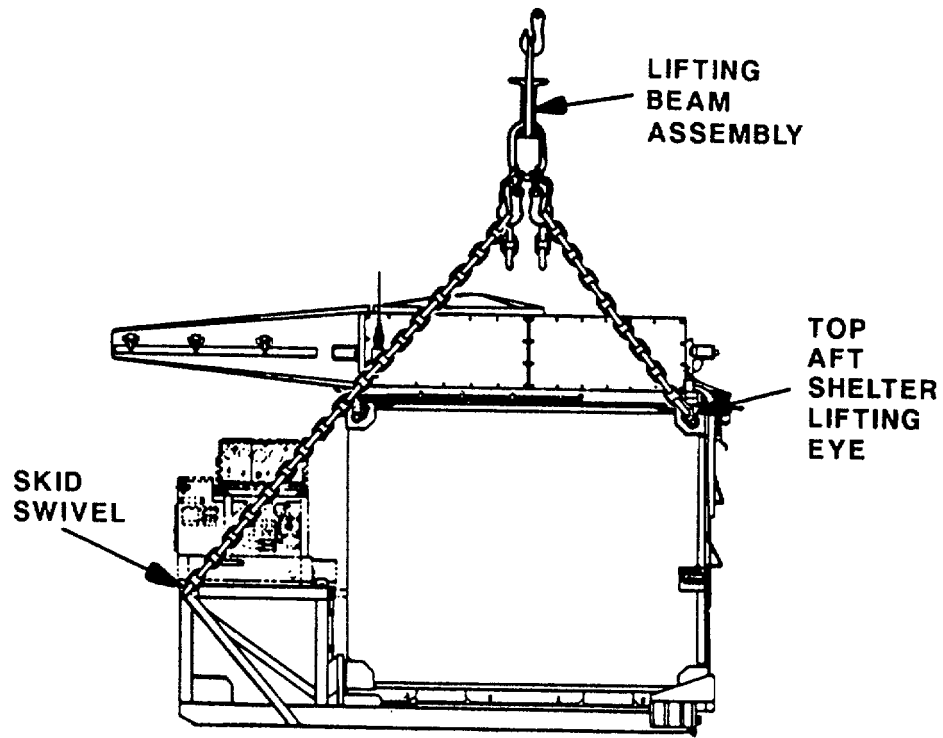
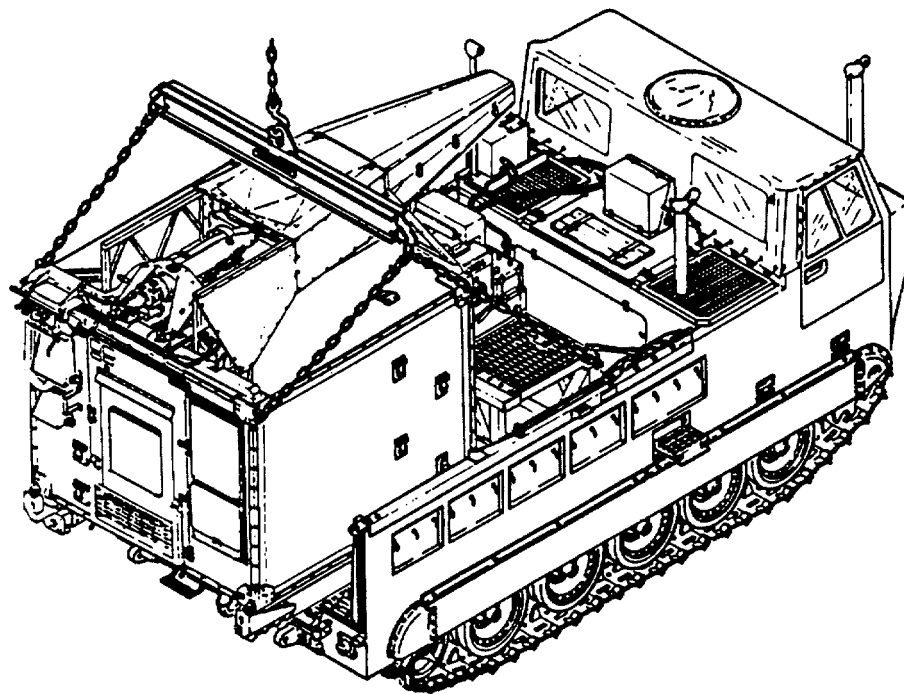

Figure 6-2. Lifting diagram for M1015 carrier with shelter attached, by use of lifting beam and wire-rope slings with spreader bar.



SIDE VIEW



REAR TOP VIEW

Figure 6-3. Lifting diagram for -103C TEAMPACK shelter.

(2) *Lightweight TEAMPACK/M1028 CUCV.* The CUCV has four lifting points: two are on the front bumper and two are on the rear bumper. Use a size 60 longitudinal spreader bar to prevent damage to the truck's grill and hood. The frame modification kit must be on all vehicles that are to be lifted. The kit enhances the vehicle's structural integrity for crane lifting operations. Each vehicle must be visually checked to see if the kit has been mounted. Figure 6-4 shows the procedure for lifting the vehicle.

b. *Loading.* The TEAMPACK and lightweight TEAMPACK systems shall be loaded onto vessels in their minimum reduced height configuration. They can be loaded onto loading craft, beach discharge and amphibious lighters, and loading ships under their own

power or by a crane of adequate capacity. Shoreside or floating cranes are required to lift the systems onto decks of barges. The systems can be loaded onto seagoing vessels by shoreside or floating cranes of adequate capacity. Jumbo booms and heavy-lift ship's gear may be used to load these systems onto vessels. They can be loaded under their own power or towed onto RORO vessels. The M1015 carrier should be equipped with rubber pads. Vessel deck surfaces should be dry and free of grease and debris.

(1) *Cargo Vessels.* Typical blocking details for securing the TEAMPACK and lightweight TEAMPACK systems are shown in figures 6-5 and 6-6, respectively. Materials and their applications are shown in tables 6-1 through 6-4.

Table 6-1. *Bill of Materials for Blocking of TEAMPACK Carrier in Hold of General-Cargo Vessel (Fig 6-5)*

Item	Description	Approximate Quantity
Lumber	Douglas-fir or comparable, straight-grain free from material defects; Fed Spec MM-L-751: 4- x 6-inch	4 feet
	2- x 10-inch	44 feet
	6- x 8-inch	120 feet
Nails	Common, steel, flathead; bright or cement-coated; type II, style 10, Fed Spec FF-N-105: 20d	20
	40d	116

Table 6-2. *Application of Materials for Blocking of TEAMPACK Carrier in Hold of General-Cargo Vessel (Fig 6-5)*

Item	No. Required	Application
A	4	Lumber, 2- x 10- x 132-inch. Pre-position on floor of vessel hold, under vehicle treads. Two pieces are required under each tread. (This application is not to be used if tracks have rubber pads.)
B	2	Side blocks. Each consists of one piece of 6- x 8-inch x length cut-to-suit lumber. Locate one piece against outside of vehicle treads, on each side of vehicle.
C	2	End blocks. Each consists of one piece of 6- x 8-inch x length cut-to-suit lumber. Locate on top of item B, against vehicle treads (front and rear).
D	4	Toenail to item B with four 40d mails, at each end.
E	as required	Backup cleats, 4- x 6- x 12-inch lumber. Locate on top of item B, against item C. Toenail to item B with four 40d nails, at each end.
		Bracing, 6- x 8-inch x length cut-to-suit lumber. Brace as required against vehicle blocking, against side of vessel, or against adjacent cargo blocking, to immobilize vehicle and blocking. Secure each end to adjacent bracing or blocking by toenailing with 40d nails.

Table 6-3. *Bill of Materials for Blocking of Lightweight TEAMPACK System in General-Cargo Vessel (Fig 6-6)*

Item	Description	Approximate Quantity
Lumber	Douglas-fir, or comparable straight-grain, free from material defects; Fed Spec MM-L-751: 4. x 4-inch	60 linear feet
Nails	Common, steel, flathead; bright or cement-coated; Fed Spec FF-N-105B: 20d	20
	50d	20

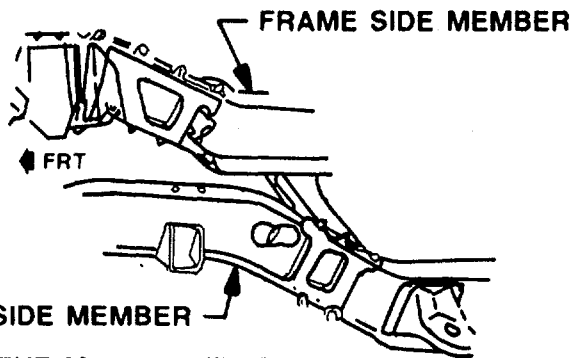

FRAME SIDE MEMBER

NOTE: THE M1028 AND M1028A1 CUCVS MANUFACTURED BEFORE MARCH 1985 MUST HAVE THE FRAME REINFORCEMENT BRACKET APPLIED BEFORE THEY MAY BE LIFTED AT GROSS VEHICLE WEIGHT.

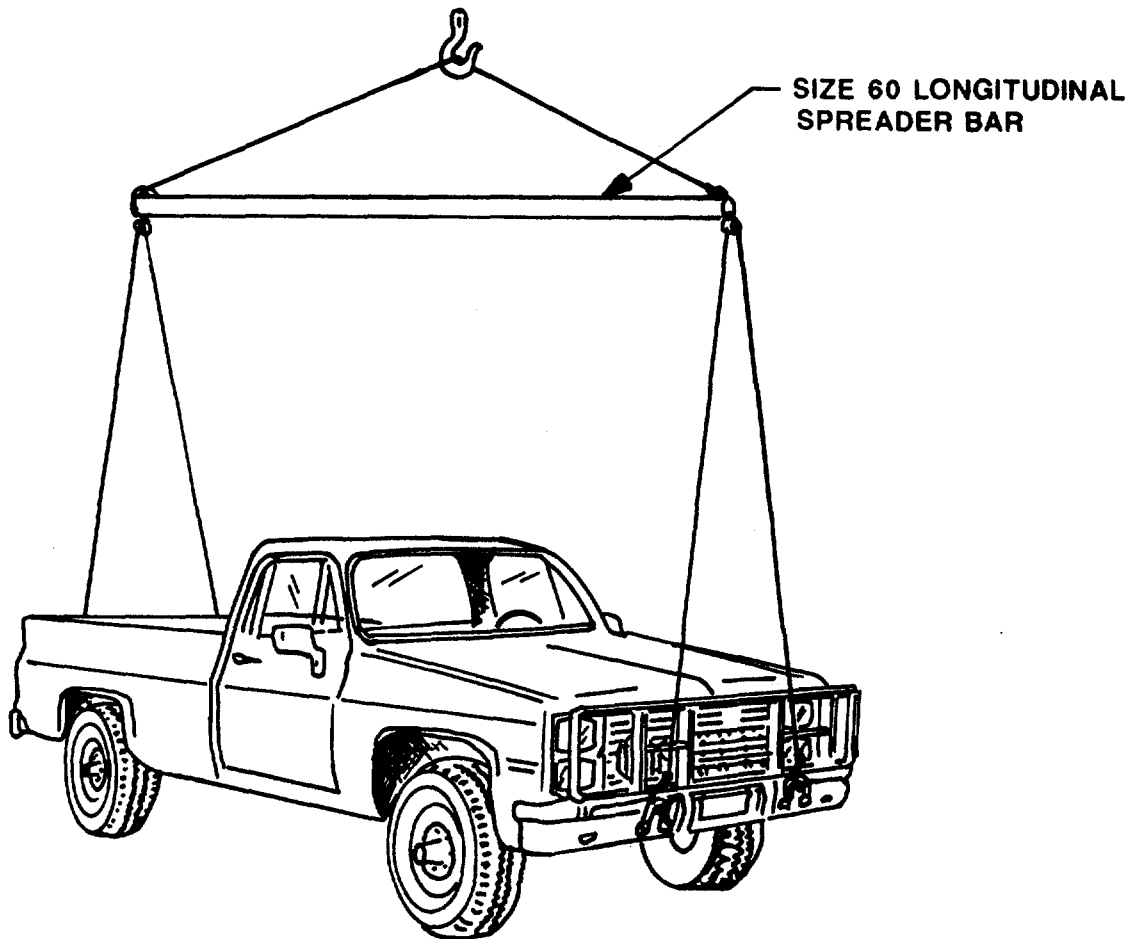

Figure 6-4. CUCV lifted by a four-legged sling and a spreader bar.

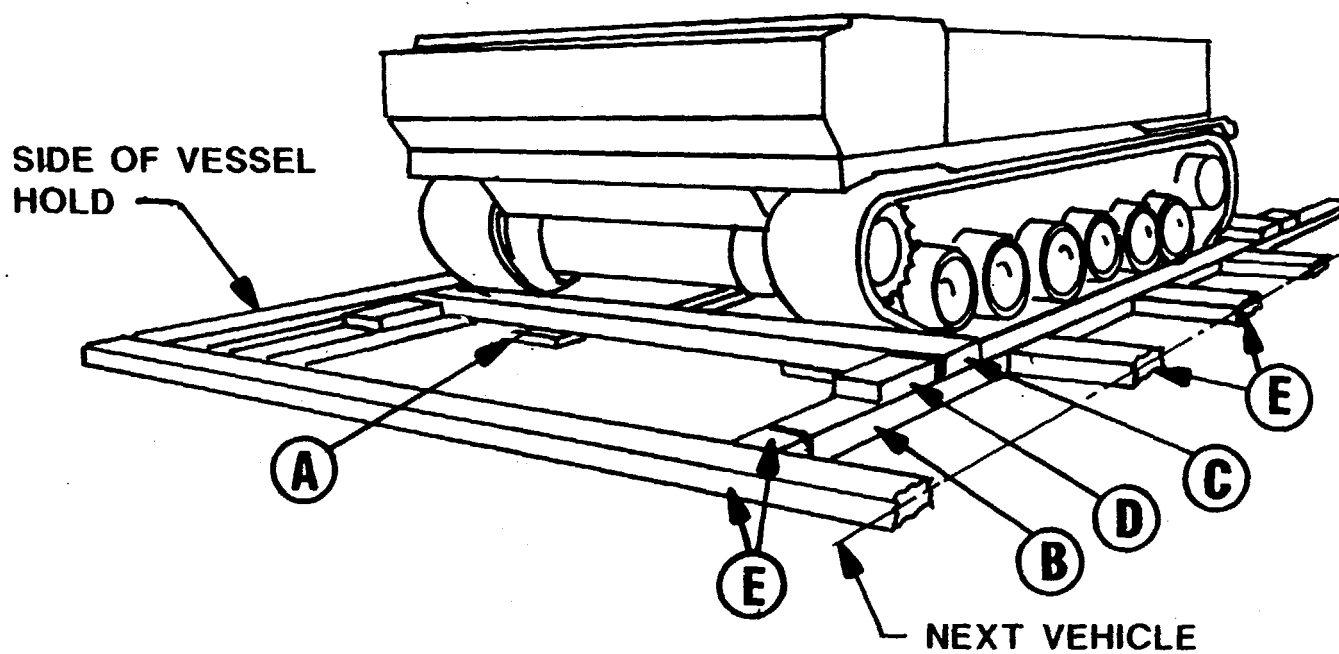

Figure 6-5. Typical blocking of TEAMPACK carrier in hold of general-cargo vessel

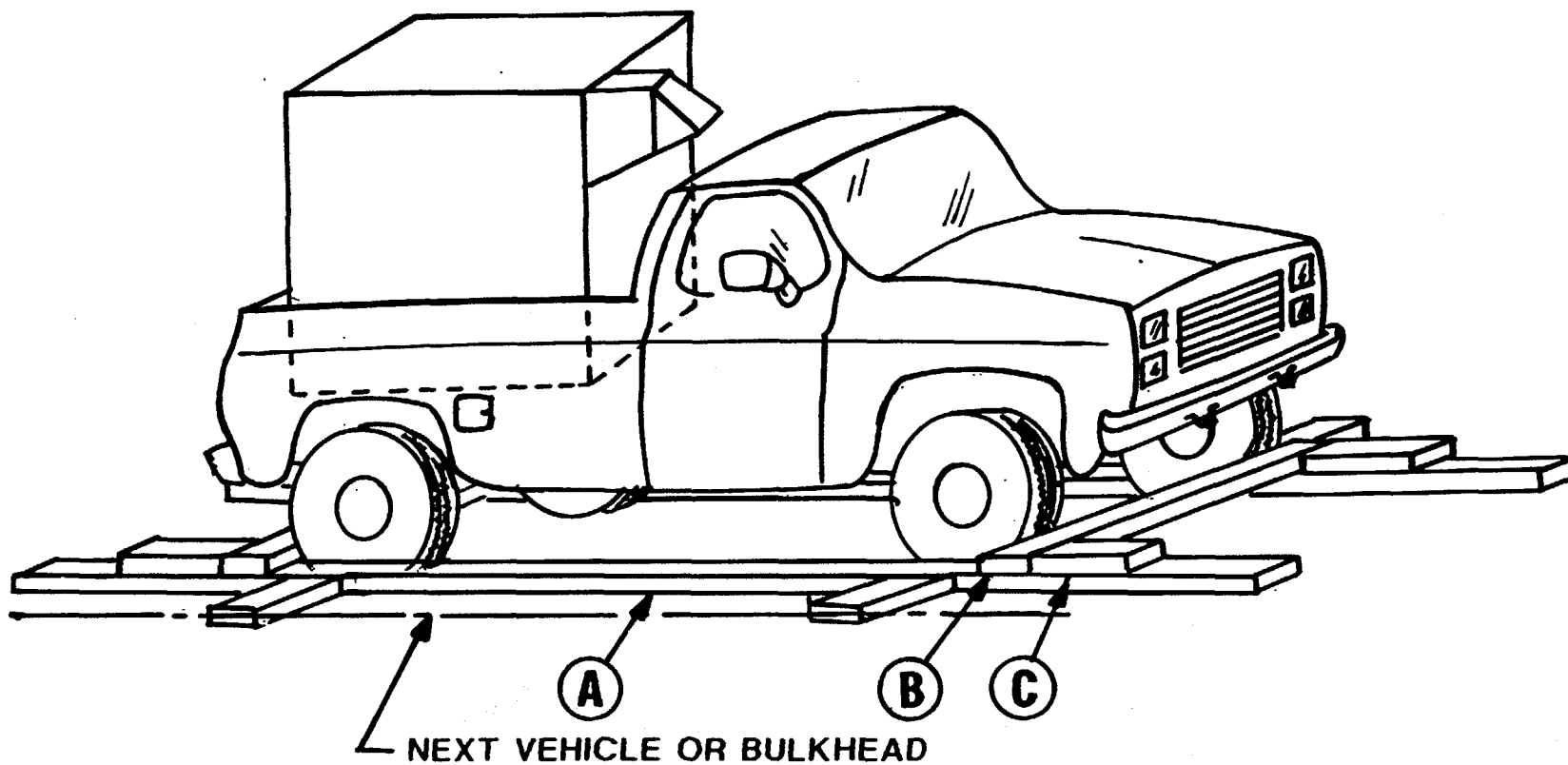

Figure 6-6. Typical blocking of lightweight TEAMPACK system in hold of general-cargo vessel

Table 6-4. Application of Materials for Blocking of Lightweight TEAMPACK System in General-Cargo Vessel (Fig 6-6)

Item	No. Required	Application
A	2	Side blocks. Each consists of 4- x 4- x 238-inch lumber. Locate one piece against outside wheels on each side.
B	2	End blocks. Each consists of 4- x 4- x 64-inch lumber. Locate on top of item A and against wheels as shown in figure 6-2. Nail to item A with four 50d nails at each end of item B.
C	4	Backup cleats. Each consists of 4- x 4- x 12-inch lumber. Locate on top of item A against the joint of each item B. Toenail to each item A with four 20d nails.

(2) *Special Design Vessels.* All seatrailer vessels, RORO vessels, landing ships, and attach-cargo vessels are equipped with patented lashing gear and pre-positioned fittings in the deck. With proper application of patented lashing gear (as shown in figs 6-7 and 6-8), blocking and bracing are not required. The M1015 tracks should be equipped with proper rubber padding.

(3) *Loading Ships, Landing Craft, and Amphibious Vehicles.* When the systems are to be moved extended distances or through rough waters, tiedowns must be used. Most vessels are equipped with turnbuckles with a sheep's foot on one end that fits into a deck cloverleaf. A suitable substitute may be used where turnbuckles are not provided.

(4) *Barge-Type (LASH and SEABEE) Ships.*

(a) *TEAMPACK*

1. The TEAMPACK system may arrive at the processing area with hatches padlocked shut to prevent pilferage. Since this vehicle cannot maneuver under its own power, its tracks are not braked and transmission is set in the neutral position to permit towing in the loading area. Contrary to normal stowage, idler wheel chocks should be in place when the system is positioned by crane in its final stow location. Rubber pads should be of a sufficient depth to prevent metal contact with the deck.

2. Floating barges noticeably tilt when heavy items are placed aboard them. Tracked vehicles should be loaded by placing one at one end and the next at the other end. This process should be repeated until all are loaded. Vehicles may have to be loaded side by side facing opposite directions if the center of balance cannot be centered in the barge using the stated procedures.

3. The TEAMPACK system may be adequately blocked and braced with 6x 8-inch timbers. If the load orientation permits, blocking may be installed as a separator between the vehicle track and the barge bulkhead. Blocking usually is installed in front of and in rear of the tracks, and the bracing part is force-fitted to the bulkhead. Loading, blocking, and bracing begin from the outer areas of the barge toward the center. A single separator timber is installed against the tracks of the vehicle, and the next vehicle loaded is placed firmly against the timber. The vehicles shall be secured with wire rope and turnbuckles as shown in figure 6-9. The void area remaining in the center of the barge after the final vehicle has been loaded shall be filled (fig 6-10) by cut and force-fitting blocking.

(b) *Lightweight TEAMPAC.* When the lightweight TEAMPACK systems are to be transported by barge for a long distance or through rough waters, they will be blocked and tied down as shown in figure 6-11.

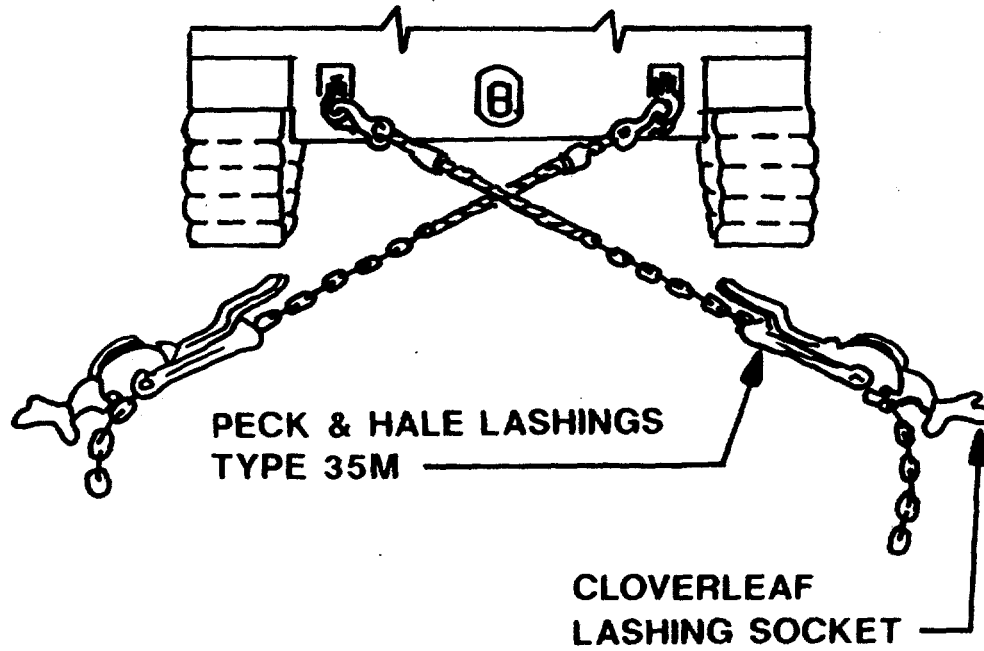

Figure 6-7. Typical tiedown of tracked cargo carrier on RORO vessel, showing typical securement with patented lashing.

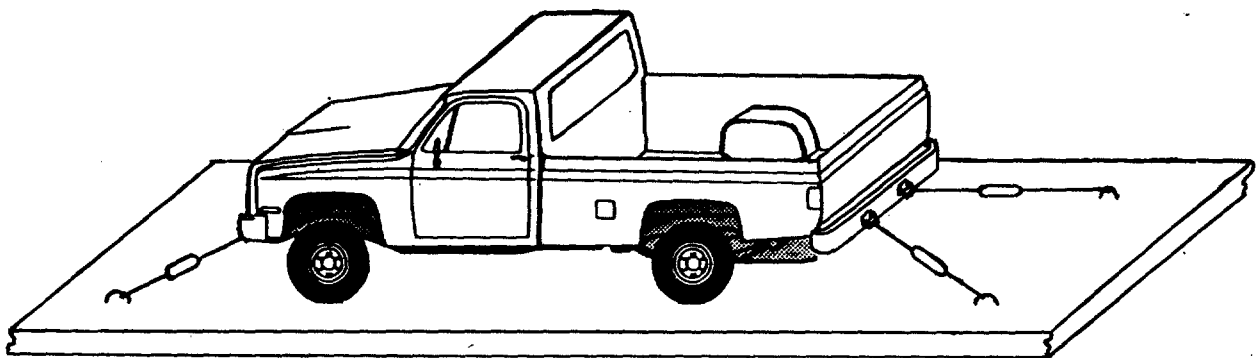

Figure 6-8. Typical tiedown of CUCV in RORO vessel

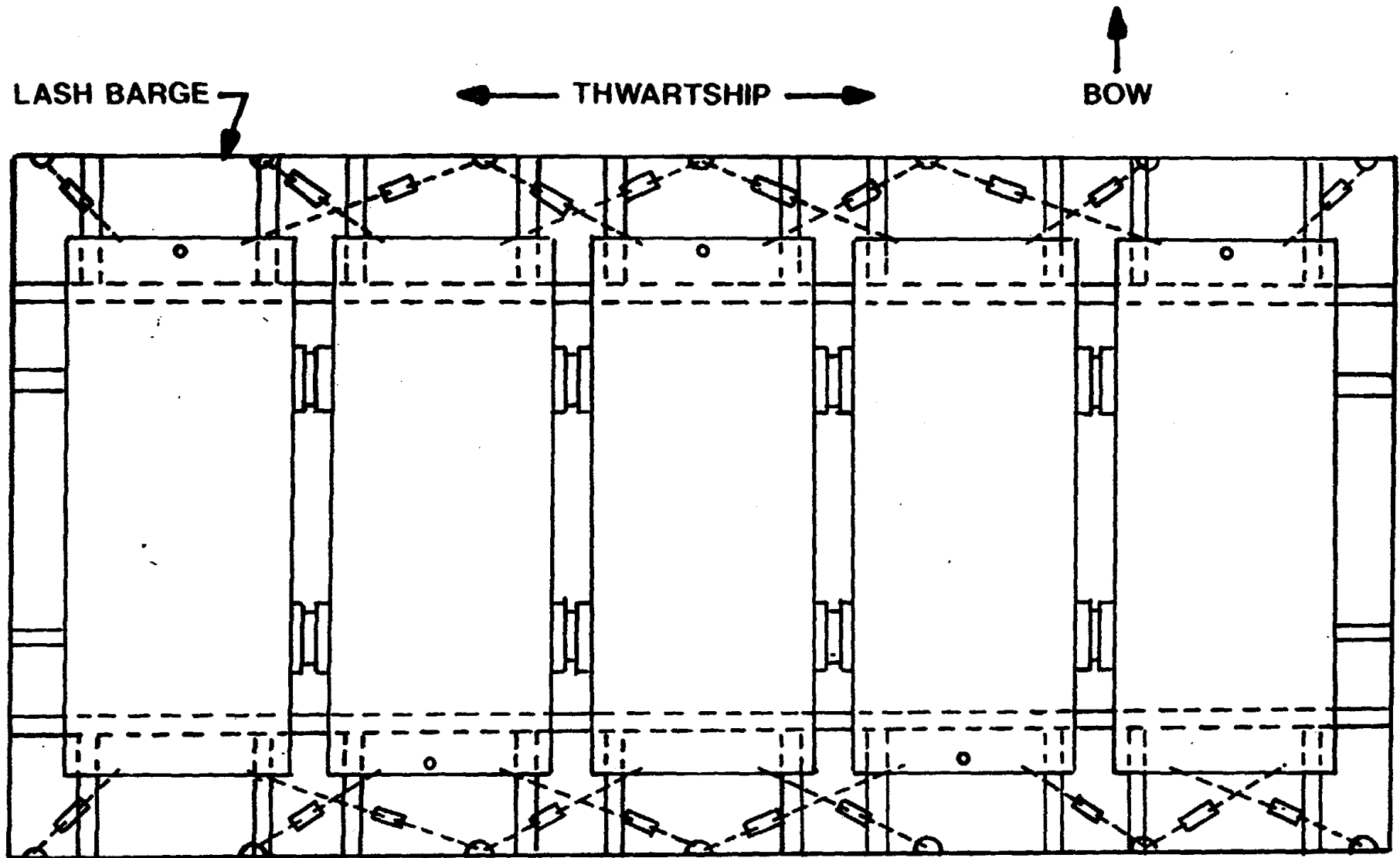

Figure 6-9. Typical loading of five TEAMPACK carriers on a LASH by use of a wire rope, cable clips, and turnbuckles, with blocking between vehicles and between vehicles and hull.

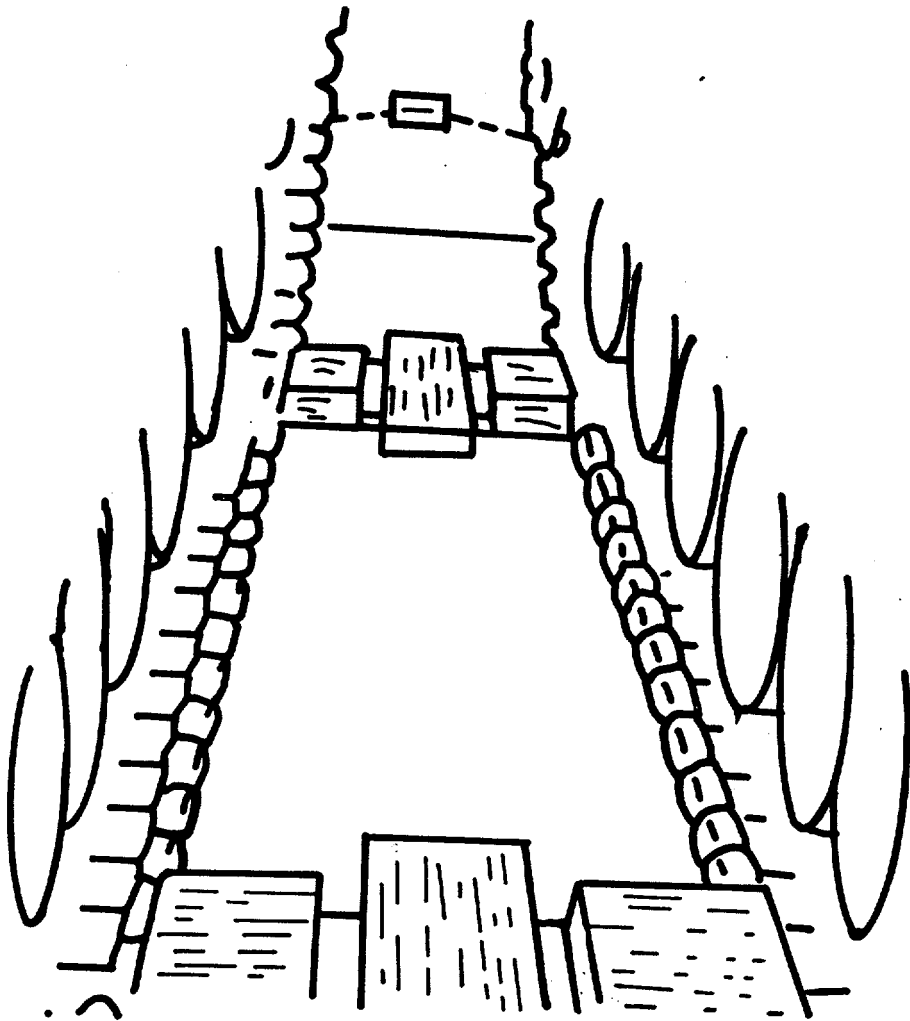
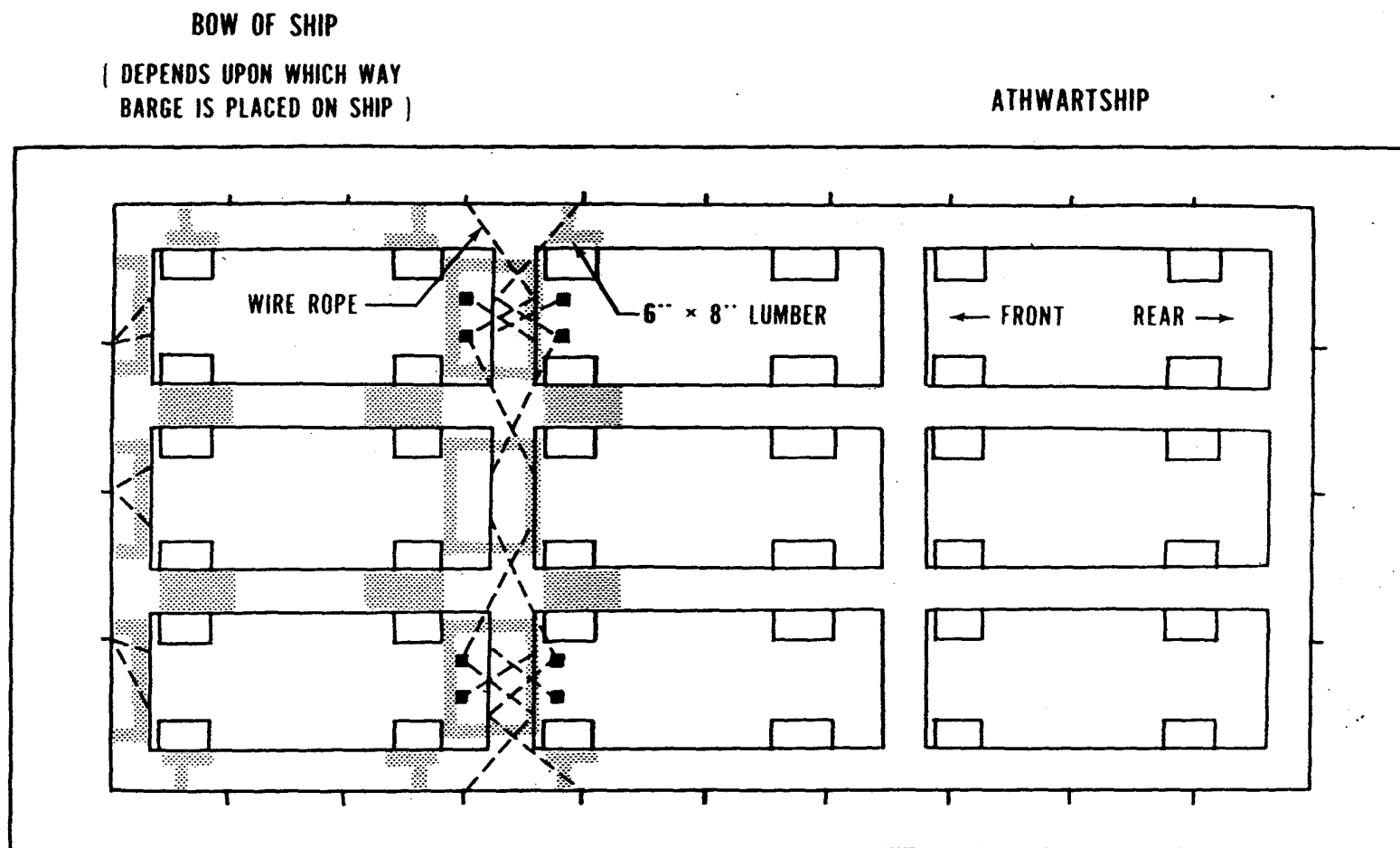

Figure 6-10. Filling center void or TEAMPACK-to-hull void area.



**BLOCKED AND BRACED WITH 6" X 8" LUMBER,
LENGTH CUT-TO-FIT AND FORCE FITTED.
TIE DOWN WITH 5/8" WIRE ROPE AND 5/8"
CABLE CLAMPS AND TURNBUCKLES.**

**THIS END OF BARGE BLOCKED, BRACED, AND
TIED DOWN THE SAME AS OTHER END OF BARGE.**

Figure 6-11. Typical blocking and tiedown of lightweight TEAMPACK in SEABEE barge.

CHAPTER 7

RAIL TRANSPORTABILITY GUIDANCE

Section I. GENERAL

7-1. Scope

This chapter provides rail transportability guidance for movement of the AN/MSQ-103A/C and AN/MSQ-103B model TEAMPACKs plus their prime movers, the M1015 tracked carrier, M925A1 5-ton truck, and M1028 CUCV. It covers significant technical and physical characteristics and safety precautions. It also prescribes the materials and guidance to prepare, load, tie down, and unload the vehicles.

7-2. Maximum Utilization of Railcars

Additional cargo, as approved by the activity offering the equipment for transport, may be transported with the system.

7-4. General

The transportability guidance contained in this section is applicable when the M1015 carrier, M925A1 5-ton truck, and M1028 CUCV are transported on CONUS railways. Consideration is given to single and multiple-vehicle movements on the type of railcars normally used for the movement of Army equipment. These vehicles, at reduced configurations, can be transported in accordance with the Association of American Railroads (AAR) Outline Diagram for Single Loads Without End Overhang on Open-Top Cars, as shown in both the railway line clearance publication and the official railway equipment register. The -103A/B/C TEAMPACK shelters also meet the AAR rail outline diagram.

7-5. Loading on Wood-Deck Flatcars

a. M1015 Carrier. The carrier may be placed in the tiedown position on the railcar by a crane or driven or towed, provided suitable ramps or bridges are available. Chapter 6 provides lifting diagrams. Figure 7-1 shows blocking and tiedown of the M1015 carrier on a wood-deck flatcar. Tables 7-1 and 7-2 provide the bill and application of materials for securing the M1015 carrier.

b. M925A1 5-Ton Truck. To load and secure this vehicle on general-purpose flatcars, refer to TM 55-2320-272-14-1.

c. M1028 CUCV. The CUCV can be driven or towed onto the railcar if suitable ramps or bridges are

7-3. Safety

In addition to the safety precautions contained in chapter 3, the following should also be noted.

NOTE

The AN/MSQ-103A/C and AN/MSQ-103B model TEAMPACK shelters must be removed from prime movers prior to shipment and shipped separately. The antennas on the AN/MSQ-103A and -103C model shelters will be removed and stored inside.

Section II. TRANSPORT ON CONUS RAILWAYS

available. The CUCV can be placed in the tiedown position on the flatcar with a crane of adequate capacity. Before the CUCV is lifted at its gross vehicle weight, it must be checked to see if the frame reinforcement kits have been applied. If these have been applied, the CUCV can be safely positioned on the flatcar with a crane of adequate capacity. Figure 7-2 shows blocking and tiedown of the M1028 CUCV on a wood-deck flatcar. Tables 7-3 and 7-4 provide the bill and application of materials for securing the CUCV. Figure 7-3 shows blocking and tiedown details.

NOTE

A staggered nailing pattern should be used when lumber or laminated lumber is nailed to the floor of the flatcar. Additionally, the nailing pattern for an upper piece of laminated lumber will be adjusted as required so that a nail for that piece will not be driven through, onto, or right beside a nail in the lower piece of lumber.

d. AN/MSQ-103A/C TEAMPACK Shelters. Figure 7-4 shows blocking and tiedown of three TEAMPACK modified S-280 shelters on a wooddeck flatcar. The same procedures shown to secure the S-280 shelters are applicable when securing

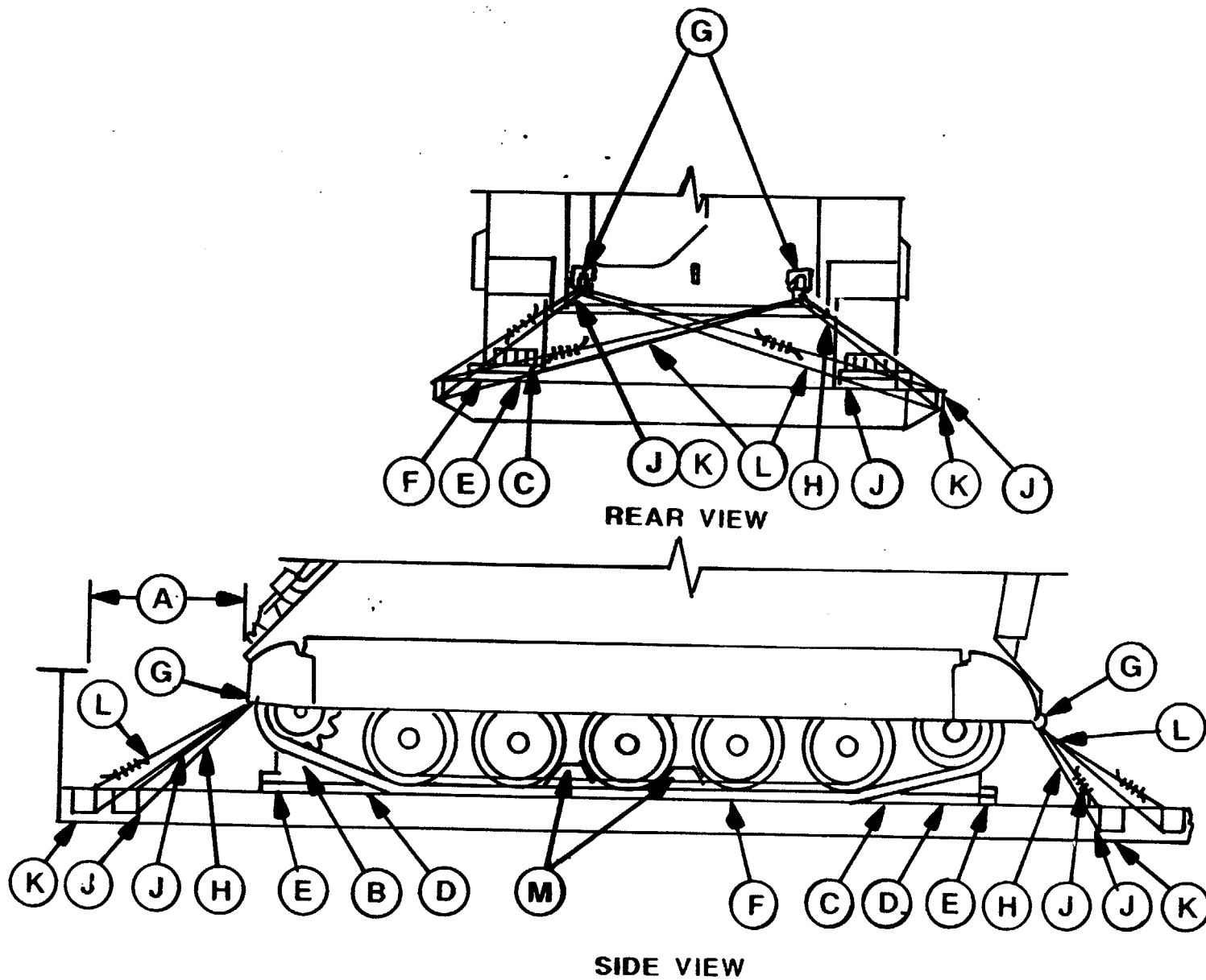

Figure 7-1. Blocking and tiedown of the M1015 carrier on a wood-deck flatcar.

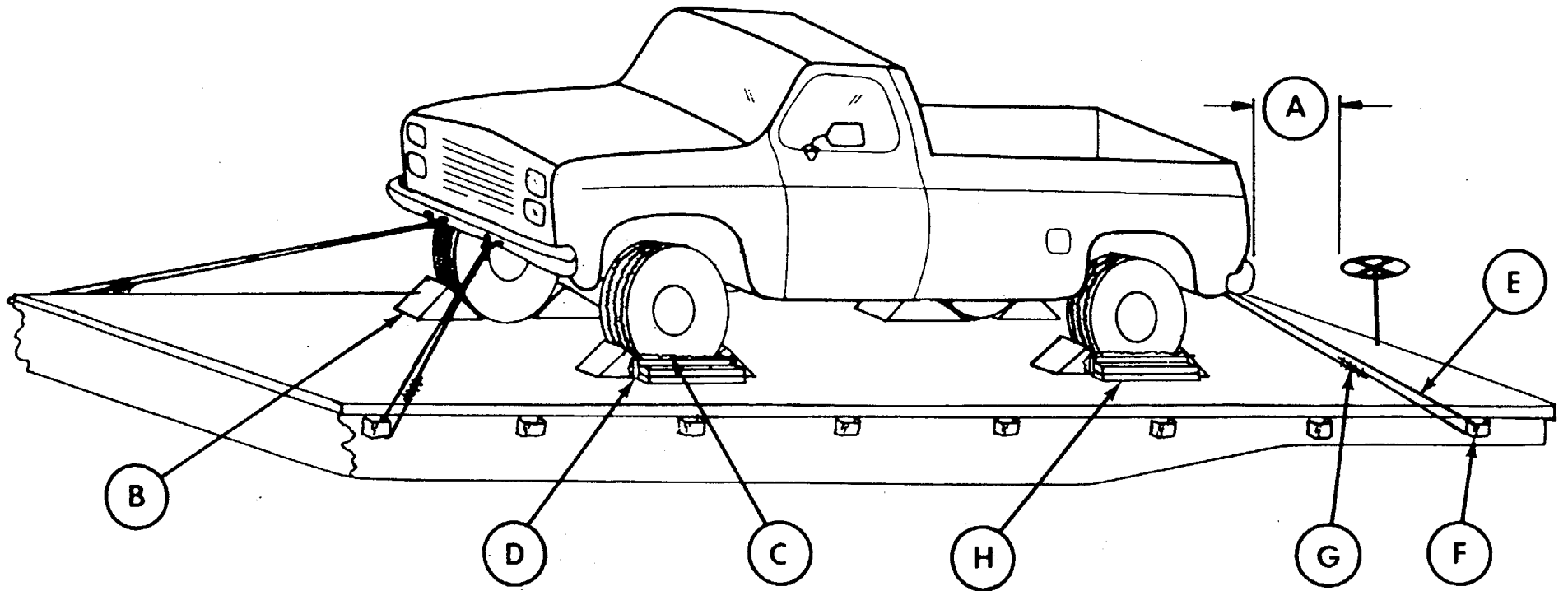

Figure 7-2. Blocking and tiedown of the M1028 CUCV on a wood-deck flatcar.

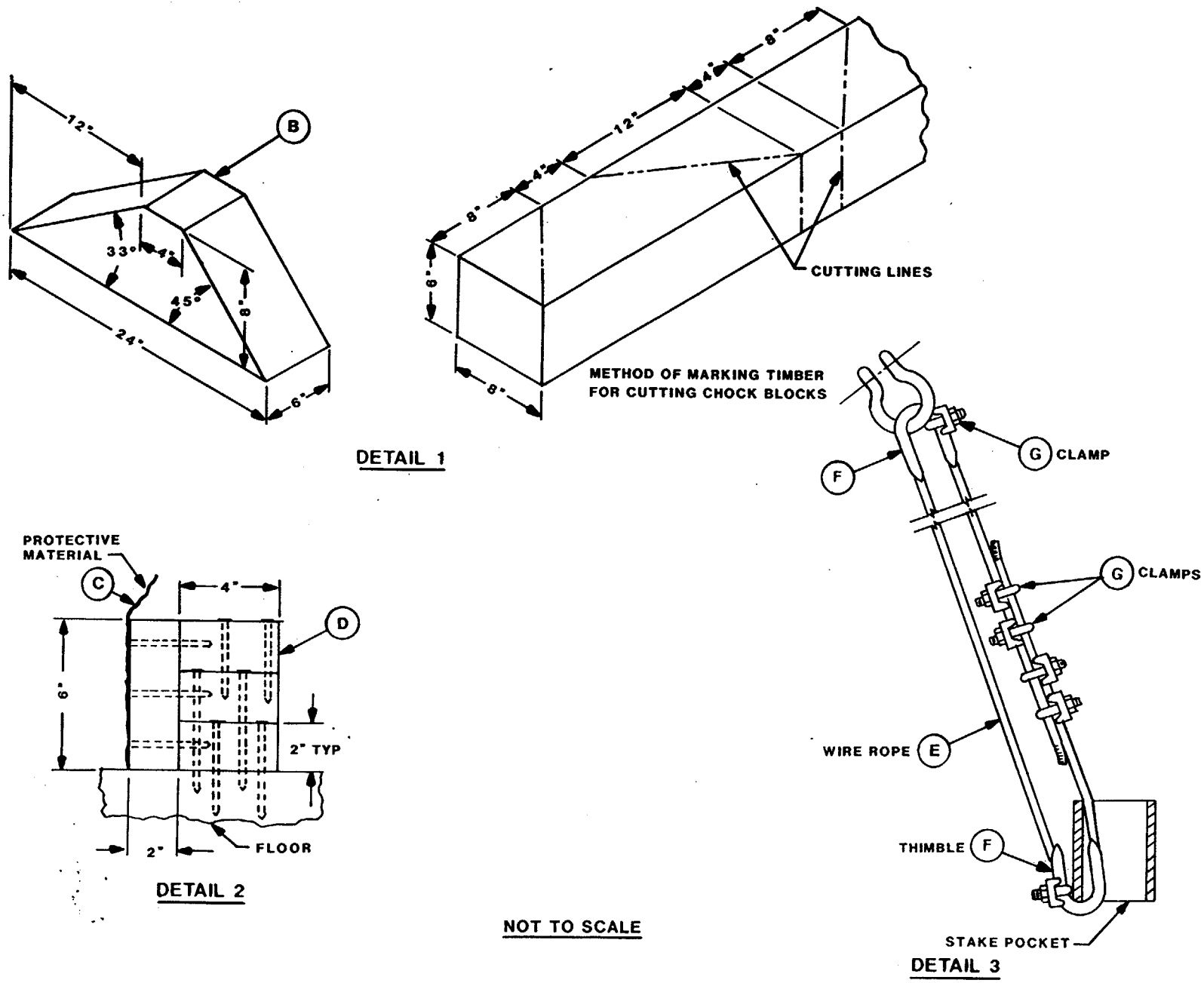

Figure 7-3. Blocking and tiedown details.

the -103A/C TEAMPACK shelters for rail transport. Tables 7-5 and 7-6 provide the bill and application of materials.

TEAMPACK shelters on a wood-deck flatcar. The same procedures shown to secure the S-250 shelters are applicable when securing the -103B TEAMPACK shelter for rail transport. Tables 7-7 and 7-8 provide the bill and application of materials.

e. AN/MSQ-103B TEAMPACK Shelters. Figure 7-5 shows blocking and tiedown of six lightweight

Table 7-1. Bill of Materials for Blocking and Tiedown of M1015 Carrier on Wood-Deck Flatcar (Fig 7-1)

Item	Description	Approximate Quantity
Lumber	Douglas-fir, or comparable, straight-grain, free from material defects; Fed Spec MM-L-751: 2- x 4-inch	52 feet
	2- x 6-inch	33 feet
	2- x 12-inch	28 feet
Nails	Common, steel, flathead; bright or cement-coated; type II, Fed Spec FF-N-105: 12d	56
	20d	32
	30d	90
	40d	16
Thimbles	Standard, open-type: 5/8-inch	16
Clamps	Wire rope, U-bolt clamps, saddled, single-grip, forged steel, Crosby heavy-duty, or equal; Fed Spec FF-C-450:5/8-inch	48
Shackles	Anchor shackles, screw-pin, type IV, class 1; Fed Spec RR-C-271; 7/8-inch (1-inch diameter pin); NSN 4030-00-162-9668	4
Wire rope	6 x 19, IWRC; improved plow steel; preformed, regular-lay; table X, Fed Spec RR-W-410: 5/8-inch	187 feet

Table 7-2. Application of Materials for Blocking and Tiedown of M1015 Carrier on Wood-Deck Flatcar (Fig 7-1)

Item	No. Required	Application
A	-	Brake wheel clearance. Minimum clearance required is 6 inches above, in back of, and on both sides of the wheel and 4 inches underneath the wheel (fig. 7-1).
B	2	Blocks (detail 1, fig 7-3). Each consists of six pieces of 2- x 12- x 28-inch lumber, cut as shown in detail 1. Nail the two inside pieces together with three 12d nails on each side. Locate one block against the front of each track as shown in figure 7-1. Toenail the heel of each block on the two inside pieces to the car floor with two 30d nails. Toenail each side of the block to the car floor with two 40d nails.
C	2	Blocks (detail 2, fig 7-3). Each consists of six pieces of 2- x 6- x 23-inch lumber, cut as shown in detail 2. Construct and apply (to rear tracks) in the same manner as item B, above.
D	8	Side cleats. Each consists of one piece of 2- x 4- x 24-inch lumber. Locate one piece on each of items B and C (flush with heel of block), and nail it to the car floor with four 20d nails.
E	4	End cleats. Each consists of two pieces of 2- x 6- x 14-inch lumber. Center the bottom pieces crosswise against the heel of items B and C, and nail them to the car floor with four 30d nails. Nail the top pieces to the bottom pieces with four 30d nails.
F	2	Side blocks. Each consists of two pieces of 2- x 4- x 108-inch lumber. Locate the bottom pieces longitudinally against the outside of each track and nail them to the car floor with 30d nails spaced about 8 inches apart. Nail the top pieces to the bottom pieces in like manner.
G	4	Shackles. Attach one shackle to each front and rear towing provision.
H	4	Wire rope. Each consists of one piece of 5/8-inch wire rope, length as required (about 15 feet). Form a complete loop between each shackle and appropriate flatcar stake pocket. (Wire rope end should overlap a minimum of 24 inches. The angle of tiedown must not be greater than 45°).
J	24	Clamps. Place four clamps on each wire rope at the overlap area, and space 3 1/2 inches apart, with a minimum of 6 inches from each end of-

Table 7-2. Continued

Item	No. Required	Application
		wire rope (detail 1, fig 7-3). Tension the wire rope and tighten the clamps to 95 foot-pounds. Use one clamp to secure each thimble to the wire rope at the stake pocket and shackle (fig 7-3).
K	8	Thimbles. Place one thimble on the wire rope at each stake pocket and shackle.
L	4	Same as item H.
M	4	Wheel blocks. Each consists of six 2- x 6- x 16-inch lumber. Cut and assemble each block as shown in detail 1, figure 7-3. Place the blocks between the road wheels (two on each track).

GENERAL INSTRUCTIONS

1. The load, as shown, is based on a flatcar with a width of 10 feet 6 inches.
2. Handbrakes must not be set.
3. Tensioning of wire rope can be accomplished with an applicable sized come-along mechanical hoist or equal tensioning device.
4. For further details, see General Rules 1, 2, 3, 4, 5, 9, 14, 15, 19A, and 19B, Section No. 1, *General Rules Governing the Loading of Commodities On Open Top Cars*, published by the Association of American Railroads.

Table 7-3. Bill of Materials for Blocking and Tiedown of CUCV on Wood-Deck Flatcar (Fig 7-2)

Item	Description	Approximate Quantity
Lumber	Douglas-fir, or comparable, straight-grain, free from material defects; Fed Spec MM-L-751: 6- x 8-inch	8 linear feet
	2- x 6-inch	8 linear feet
	2- x 4-inch	16 linear feet
Nails	Common, steel, flathead; bright or cement-coated; Fed Spec FF-N-105: 12d	12
	20d	24
	40d	40
Clamps	Wire rope, U-bolt clamps, saddled, single-grip, steel, Crosby heavy-duty, or equal; Fed Spec FF-C-450: 3/8-inch	16
Wire rope	6 x 19, IWRC; improved plow steel; preformed, regular-lay; table X, Fed Spec RR-W-410: 3/8-inch	34 feet
Cushioning	waterproof paper, burlap, or other suitable material	as required

Table 7-4. Application of Materials for Blocking and Tiedown of CUCV on Wood-Deck Flatcar (Fig 7-2)

Item	No. Required	Application
A	-	Brake wheel clearance. Minimum clearance required is 6 inches above, in back of, and on both sides of and 4 inches underneath the wheel. Also required is a 12-inch minimum clearance from end of car to load, from center of brake wheel to side of car, and 6 feet above car floor (fig 7-2).
B	8	Chock block (detail 1, fig 7-3). Place 45° portion of block against front and rear of each wheel as shown in figure 7-2. Nail heel of block to car floor with two 40d nails.
C	as required	Cushioning material (detail 2, fig 7-3). Locate so that material is under item D and extends 2 inches above item D, between tires and item D.
D	4	Side blocks (detail 2, fig 7-3). Each consists of one piece of 2- x 6- x 24-inch lumber and two pieces of item H, 2- x 4- x 24-inch lumber. Nail 2- x 6- x 24-inch piece to edge of lower 2- x 4- x 24-inch piece with four 12d nail. Place 2- x 6- x 18-inch piece against cushioning material and tire, and nail to car floor in a staggered pattern through 2- x 4- x 18 inch piece with four 20d nails. Nail upper 2- x 4- x 24-inch piece to lower piece with four 20d nails.
E	4	Tiedowns (detail 3, fig 7-3). Each consists of one piece of 3/8-inch 6 x 19, IWRC wire rope, length as required (about 15 feet). Form a complete loop between truck tiedown and appropriate stake pocket at a maximum angle of 45°. Wire rope should overlap about 20 inches.

Table 7-4. Continued

Item No.	Required	Application
F	4	Thimbles. Place one thimble under wire rope at each place where rope passes under bottom edge of stake pocket. Secure each thimble to wire rope with one 3/8-inch clamp (detail 3, fig 7-3).
G	16	Clamps. Place four on each item E at overlap area. Space clamps 2 1/2 inches apart, with at least 6 inches from ends of wire rope (detail 3, fig 7-3). Place one on each item G as indicated above. Torque all clamps to 45 foot-pounds.
H	8	Side blocks (detail 2, fig 7-3). Each consists of two pieces of 2- x 4- x 24-inch lumber assembled as described in item D.

GENERAL INSTRUCTIONS

1. Set handbrakes and block or wire lever in place.
2. General Rules 1 through 5, 14, 15, 19A, and 19B, Section 1, *General Rules Governing the Loading of Commodities On Open Top Cars*, published by the Association of American Railroads, apply.
3. Tension wire rope with an applicable sized come-along mechanical hoist or equal tensioning device.

Table 7-5. Bill of Materials for Blocking and Tiedown of Three TEAMPACK Shelters on Wood-Deck Flatcar (Fig 7-4)

Item	Description	Approximate Quantity
Lumber	Douglas-fir, or comparable; straight-grain, free from material defects:	
	Wedges (to suit)	6
	Block stakes (to suit)	6
	Blocks, 6- x 6-inch (to suit)	10
	Blocks, 2- x 6-inch x 10-foot (to suit)	6
	Blocks, 4- x 4-inch x 14-foot (side blocks)	6
	Blocks, 6- x 6- x 16-inch (2 each end of shelter, outside)	12
	Blocks, 6- x 8-inch (to suit) between shelters	12
Nails	Common, steel, flathead; bright or cement-coated; Fed Spec FF-N-105B: 20d	80
	80d	60
	40d	60
Thimbles	Standard, open-type: 3/8.inch	24
Clamps	Wire rope, U-bolt clamps, saddled, single-grip, steel, Crosby heavy-duty, or equal; Fed Spec FF-C-450: 3/8-inch	72
Wire rope	6 x 19, IWRC; improved plow steel; preformed; regular-lay; table X, Fed Spec RR-410C: 3/8-inch	164 feet

Table 7-6. Application of Materials for Blocking and Tiedown of Three TEAMPACK Shelters on Wood-Deck Flatcar (Fig 7-4)

Item	No. Required	Application
A	6	Wedges. Use at each stake pocket, at both ends of railcar, to hold stake in place.
B	6	Stakes. Use at both ends of railcars to hold bracing material in place.
C	6	Blocks, 6- x 6-inch. Three blocks for holding shelter in place and cut to suit for each end of railcar.
D	4	Blocks, 6- x 6-inch. Two each for each end of railcar. Attach to the above block to hold shelter in place.
E	6	Blocks, 2- x 6- x 10-inch side block for each shelter. Nail to top of 4- x 4- x 14-inch.
F	6	Blocks, 4- x 4- x 14-inch side block for each shelter.
G	12	Blocks, 6- x 6- x 16-inch. Outside corner blocks for each shelter.
H	2	Blocks, 6- x 8-inch. Lays flat between shelters.
J	164	Wire rope. Will be secured as shown in the detail. Tension the wire rope to 600-800 pounds.
K	24	Thimbles. Secure as shown in detail.
L	72	Clamps. Secure as shown in detail. Torque all clamps to 45 foot-pounds.

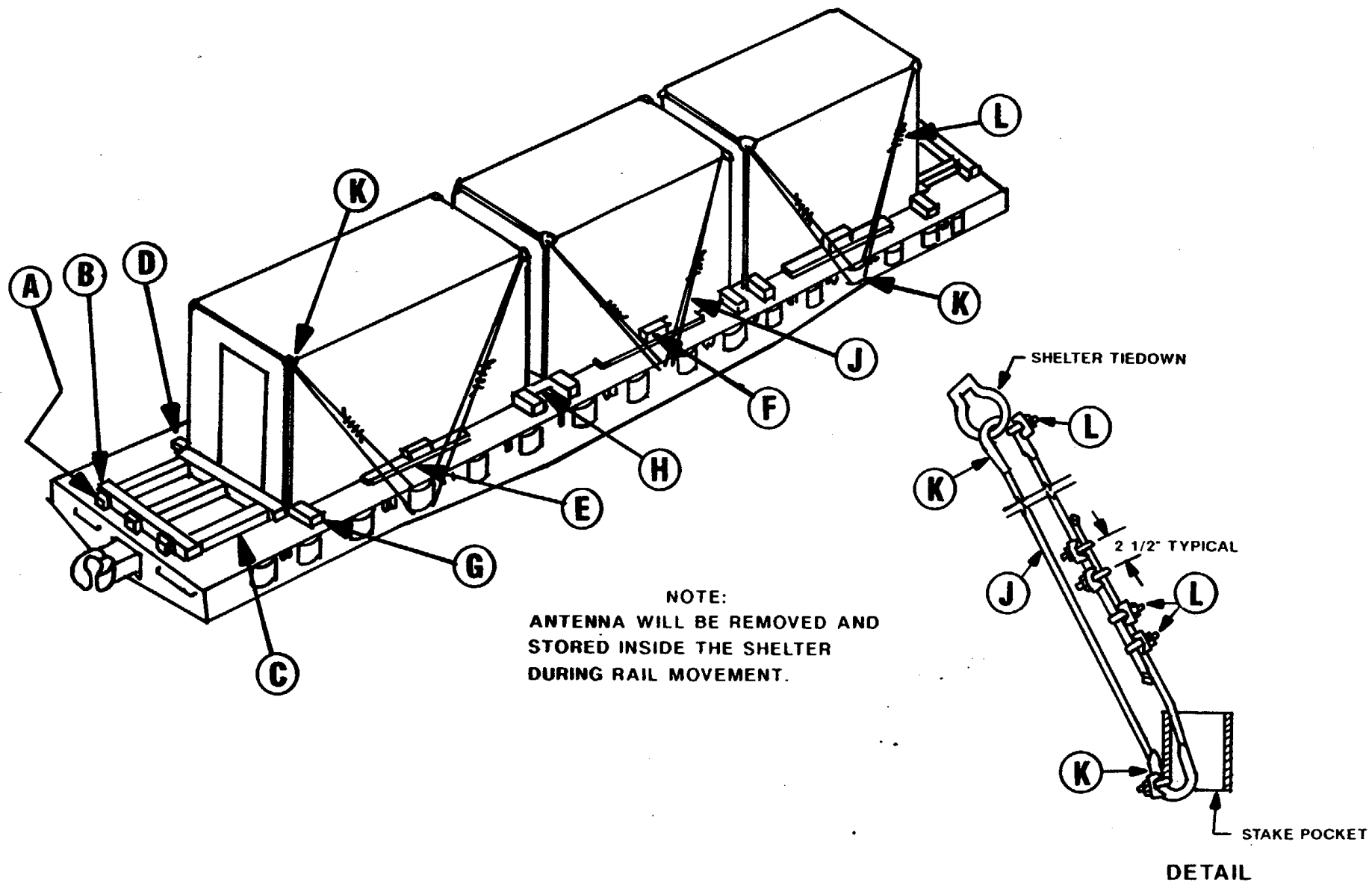

Figure 7-4. Blocking and tiedown of three TEAMPACK shelters on wood-deck flatcar.

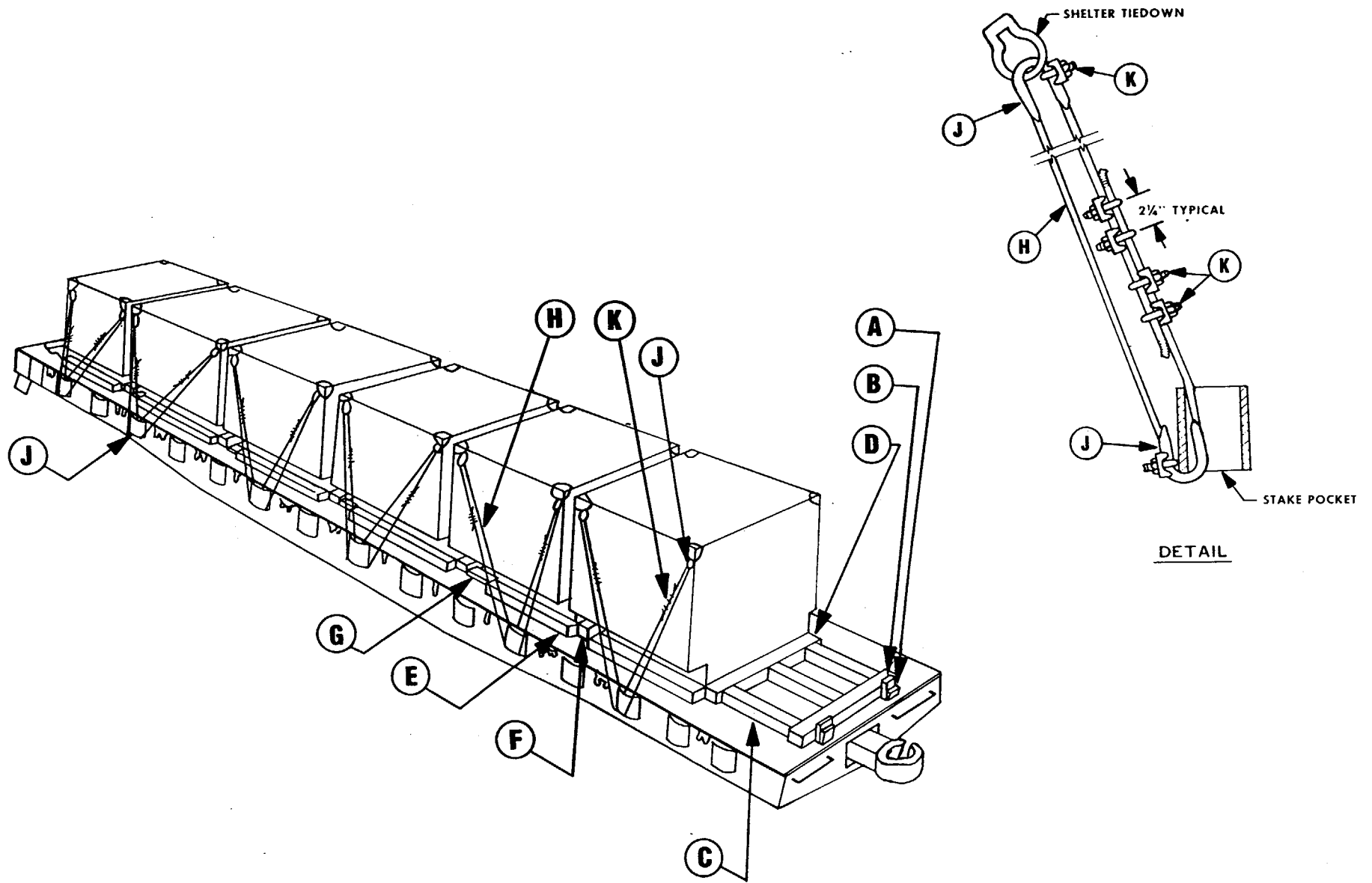

Figure 7-5. Blocking and tiedown of six lightweight TEAMPACK shelters on wood-deck flatcar.

Table 7-7. Bill of Materials for Blocking and Tiedown of Six Lightweight TEAMPACK Shelters on Wood-Deck Flatcar (Fig 7-5)

Item	Description	Approximate Quantity
Lumber	Douglas-fir, or comparable; straight-grain, free from material defects:	
	Wedges (to suit)	6
	Block stakes (to suit)	6
	Blocks, 6- x 6-inch (to suit)	10
	Blocks, 4- x 4-inch x 38-foot (side blocks)	12
	Blocks, 4- x 4-inch x 64-foot (between shelters)	10
	Blocks, 2- x 4-inch (to suit), corner of shelters	10
Nails	Common, steel, flathead; bright or cement-coated; Fed Spec FF-N-105B: 20d	128
	30d	60
	40d	60
Thimbles	Standard, open-type: 3/8-inch	48
Clamps	Wire rope, U-bolt clamps, saddled, single-grip, steel, Crosby heavy-duty, or equal; Fed Spec FF-C-450: 3/8-inch	144
Wire rope	6 x 19, IWRC; improved plow steel; preformed; regular-lay; table X, Fed Spec RR-410C: 3/8-inch	to suit

GENERAL INSTRUCTIONS

1. Place the blocking tight against the shelters. Nail all lumber blocking to the flatcar deck 8 inches on center, in a staggered pattern, with nails that penetrate the deck at least 2 inches.
2. Six shelters are shown and can be loaded on most wood-deck flatcars. Some flatcars are long enough to accommodate more shelters, which may be loaded by the method shown.

Table 7-8. Application of Materials for Blocking and Tiedown of Six Lightweight TEAMPACK Shelters on Wood-Deck Flatcar (Fig 7-5)

Item	No. Required	Application
A	6	Wedges, Use at each stake pocket, at both ends of railcars, to hold stake into place,
B	6	Stakes. Use at both ends of railcars to hold bracing material in place,
C	6	Blocks, 6- x 6-inch. Three blocks for holding shelter into place and cut to suit for each end of railcar.
D	4	Blocks, 6- x 6-inch. Two each for each end of railcar. Attached to the above blocks to hold shelter in place.
E	12	Blocks, 4- x 4- x 48-inch, for sides of shelter.
F	10	Blocks, 4- x 64- x 48-inch. Two blocks between each pair of shelters.
G	10	Blocks, 2- x 4-inch, for corners of shelter.
H	24	Wire rope. Secure as shown in the detail. Tension the wire rope to 600-800 pounds.
J	48	Thimbles. Secure as shown in detail.
K	144	Clamps. Secure as shown in detail. Torque all clamps to 45 foot-pounds.

7-6. Loading on Flatcars with Steel Decks and Center Tiedown Rails

Loading the M1015 and M1028 is the same for steel-deck flatcars as it is for wood-deck flatcars. Figures 7-6

and 7-7 show the tiedown for each vehicle on steel-deck flatcars. Tables 7-9 and 7-10 show the bill and application of materials.

Section III. TRANSPORT ON FOREIGN RAILWAYS .

7-7. General

The transportability guidance contained in this section is applicable when the M1015 carrier, M925A1 5-ton cargo truck, M1028 CUCV, and AN/MSQ-103A/C and AN/MSQ-103B model TEAMPACK shelters are transported on foreign railways. Consideration is given

to single and multiple-vehicle movements on the type of railcars normally used for movements of these vehicles. These items, when loaded on suitable railcars, comply with the Gabarit International de Chargement (GIC) gauge and can be transported without restriction within European countries, in most

Table 7-9. Application of Chain Tiedown for Securing M1015 Carrier on Steel-Deck, Center-Rail Flatcar (Fig 7-6)

Item	No. Required	Application
A	-	Brake wheel clearance. Minimum clearance required is 6 inches above, in back of, and on both sides of the wheel and 4 inches underneath the wheel (fig 7-6).
B	4 each unit	Shackles. For carriers having a 1-inch-diameter hole in the towing provisions, use a 1-inch-diameter pin with a 7/8-inch steel, galvanized, coated anchor shackle. For carriers having a larger hole in the towing provisions, use an appropriate size pin and shackle. Attach the shackle to the front and rear towing provisions, and secure the pin with a piece of wire (for screw pin) or cotter pin (for other types of shackles).
C	4 each unit	Devices. Use the Brandon single-chain tiedown device with 2-inch-diameter Excelloy chain, or similar, proof-tested to 27,500 pounds. Apply the chain from the shackle on the vehicle to the car rub rail (detail 1, fig 7-6). When necessary, items D and E may be substituted for item C.
D	2 each unit	Chains with turnbuckles. Attach the chains and turnbuckles to the shackles and car rub rails (detail 3, fig 7-6). Details are listed in the General Instructions.
E	2 each unit	Chains. Attach chains to the shackles and car rub rails (detail 3, fig 7-6). Details are listed in the General Instructions.

GENERAL INSTRUCTIONS

- When ordering specialized railroad freight equipment, shippers should specify cars equipped with tiedown devices along with the quantity shown in item C. If conventional chain tiedowns are provided in lieu of the tiedown devices specified in item C, they must conform to the requirements of items D and E and must be applied as follows:
 - Attach the two chain tiedowns (detail 3, fig 7-6, item E) to one end of the carrier and to the car tiedown facility. Pull as tight as possible (by hand), and attach the chain hook to an appropriate link.
 - Attach the two chain tiedowns with the adjustable turnbuckles (detail 2, fig 7-6, item D) to the opposite end of the carrier and to the car tiedown facility. Tighten the turnbuckles to make all four chain tiedowns taut.

NOTE

Load binders are not to be used instead of turnbuckles in tension tiedown chains.

- Carriers must face in the same direction and must be uniformly spaced along the length of the car to allow sufficient space for tiedown at each end of the car and between the carriers. Tiedowns must be applied parallel to each other at the same end of the carrier and down from the carrier point of attachment to the car tiedown facility. The angle of the tiedown chain must not be greater than 45°.
- Handbrakes on carriers must not be set.
- Gearshift levers must be placed in the neutral position.
- Open hooks on chains must be secured with wire over the opening to prevent the hook from becoming disengaged from the chain link to which it is attached.
- Turnbuckles not equipped with self-locking devices must be wired or locked to prevent them from turning during transit.
- Carriers weighing up to 25,000 pounds each, in the quantities shown below, can be loaded on 85-foot or longer cushioned rub-rail cars or similar flatcars, with center tiedown positions running the entire length of the car.

<i>Model</i>	<i>No. per 85-foot car</i>	<i>No. per 89-foot car</i>
<i>M1015</i>	<i>3</i>	<i>4</i>

- For further details, see General Rules 4, 5, 7, and 19A, Section 1, *General Rules Governing the Loading of Commodities On Open Top Cars*, published by the Association of American Railroad.

Table 7-10. Application of Chain Tiedown for Securing CUCV on Steel-Deck, Center-Rail Flatcar (Fig 7-7)

Item	No. Required	Application
A	-	Brake wheel clearance. Minimum clearance required is 6 inches above, in back of, and on both sides of and 4 inches underneath the wheel.
B	4 each	Steel chains. Use a 3/8-inch-diameter alloy steel chain, extra strength, proof-tested to a minimum of 18,000 pounds, or use either a 1/2-inch-diameter alloy steel chain, proof-tested to a minimum of 22,500 pounds, or a 1/2-inch-diameter alloy steel chain, extra strength, proof-tested to a minimum of 27,500 pounds. Attach one chain tiedown to each tiedown shackle in front and rear.

GENERAL INSTRUCTIONS

When ordering specialized railway equipment, shippers should specify cars equipped with tiedown devices in the quantity and strength as shown in item B. When carriers furnish cars that do not have built-in chains and tensioning devices, chains shown in item B will be used to secure vehicles. Tiedown chains must be checked for twisted or kinked links before they are applied to the vehicles.

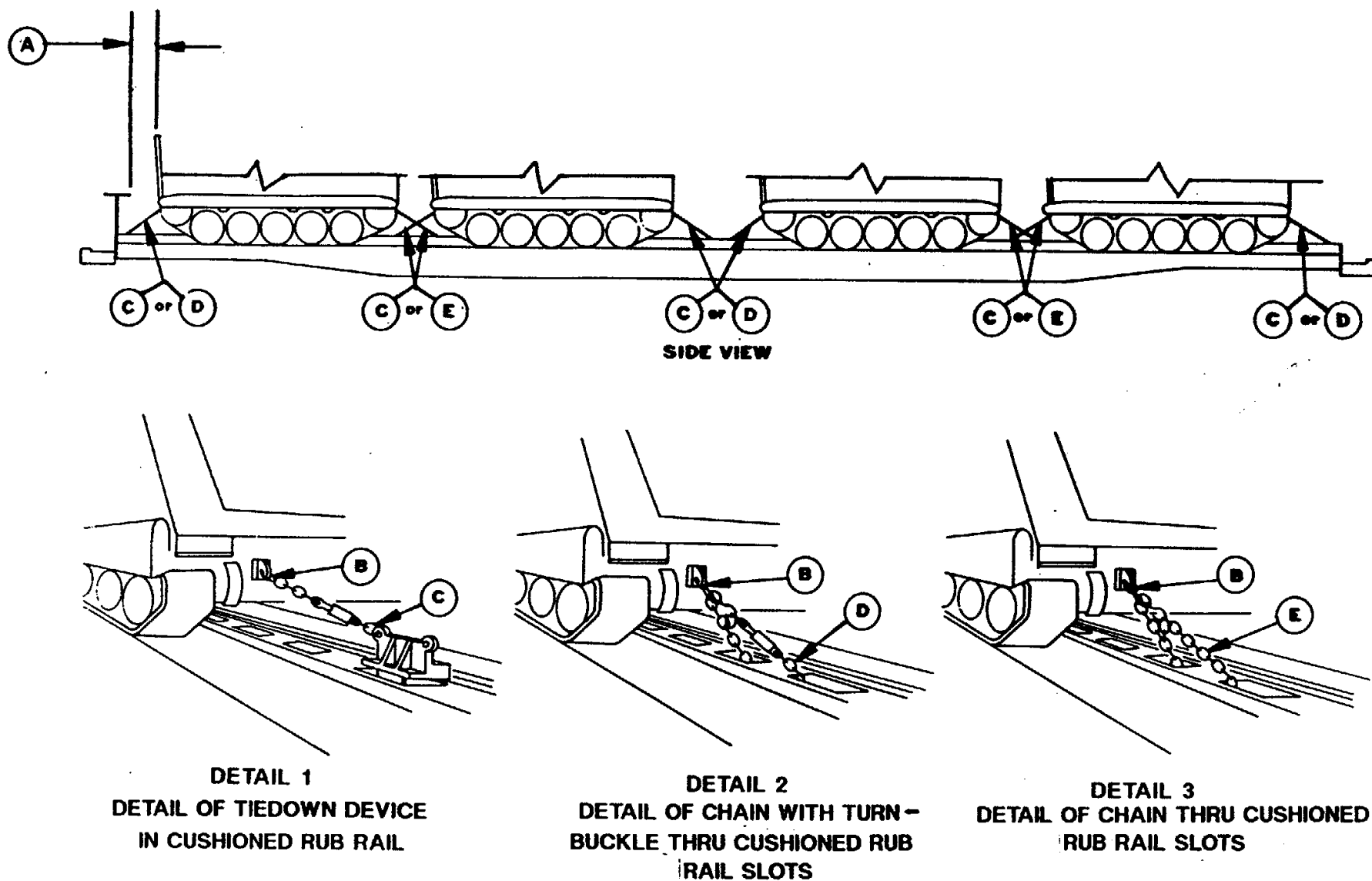

Figure 7-6. Tiedown of M1015 carrier on steel-deck, center-rail flatcar.

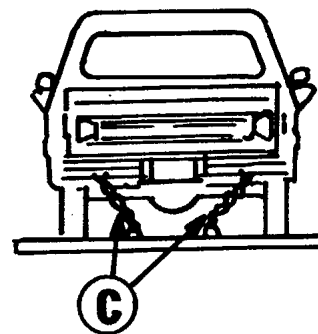
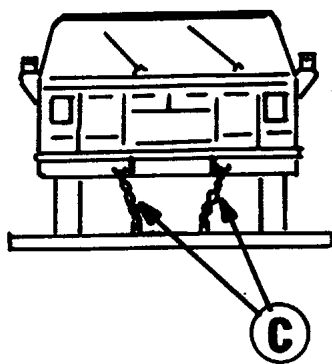
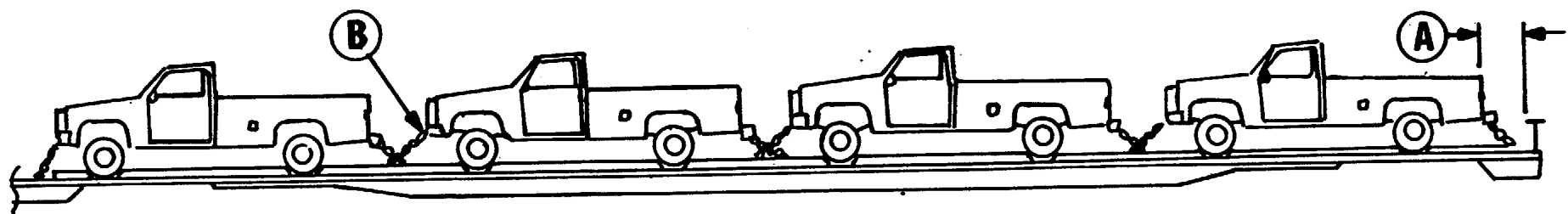

Figure 7-7. Tiedown of M1028 CUCV on a steel-deck, center-rail flatcar.

countries in the Middle East, and in South America, Australia, India, and Pakistan. In the Middle East and South America, the clearance varies by country; each country will require a separate check. In Australia and India, wide or broad gauge railways provide greater clearances and fewer restrictions. Because of the various classification systems used by different countries, foreign railcars are not easily classified. In addition, clearances may vary from country to country; therefore, evaluation of transportability capability must be made for each country.

7-8. Transport on Foreign Flatcars

a. General. The M1015 carrier, M925A1, M1028 CUCV, and AN/MSQ-103A/C and AN/MSQ-103B TEAMPACKS can be transported on most foreign flatcars.

b. Materials. The materials required for blocking and tiedown of the vehicles and shelters on foreign flatcars are essentially the same as those used in CONUS. Guidance for loading these items of equipment on foreign railcars can be obtained from Commander, 1st Transportation Movement Control Agency, ATTN: AEUTR-MCA-TA, APO New York 09451-4000.

APPENDIX

REFERENCES

1. Technical Manuals (TM)

- 38-250 (AFR 71-4) Packaging and Materials Handling: Preparation of Hazardous Materials for Military Air Shipment
55-2320-272-14-1 Transportability Guidance, Trucks, 5.Ton, 6X6, M939- Series/M939A1-Series

2. Technical Orders (TO) (Air Force)

- 1C-130A-9 Loading Instructions, USAF Series C-130 Aircraft
1C-141B-9 Loading Instructions, USAF Series C-141 Aircraft
1C-5A-9 Loading Instructions, USAF Series C-5 Aircraft

3. Other Publications and Sources of Procurement

Association of American Railroads, Section No. 1, *General Rules Governing the Loading of Commodities On Open Top Cars*.

Available from: Association of American Railroads
American Railroads Building
50F Street, NW
Washington, DC 20001

By Order of the Secretary of the Army:

Official:

WILLIAM J. MEEHAN II
Brigadier General, United States Army
The Adjutant General

CARL E. VUONO
General, United States Army
Chief of Staff

DISTRIBUTION:

To be distributed in accordance with DA Form 12-34B, requirements for TM 55-5811-188-14.

*U.S.GOVERNMENT PRINTING OFFICE:1989-242-447:80090

RECOMMENDED CHANGES TO EQUIPMENT TECHNICAL PUBLICATIONS

 <p><i>THEN...JOT DOWN THE DOPE ABOUT IT ON THIS FORM. CAREFULLY TEAR IT OUT, FOLD IT AND DROP IT IN THE MAIL.</i></p>				SOMETHING WRONG WITH PUBLICATION	
				FROM: (PRINT YOUR UNIT'S COMPLETE ADDRESS)	
				DATE SENT	
PUBLICATION NUMBER			PUBLICATION DATE		PUBLICATION TITLE
BE EXACT PIN-POINT WHERE IT IS				IN THIS SPACE, TELL WHAT IS WRONG AND WHAT SHOULD BE DONE ABOUT IT.	
PAGE NO.	PARA-GRAPH	FIGURE NO.	TABLE NO.		
PRINTED NAME, GRADE OR TITLE AND TELEPHONE NUMBER				SIGN HERE	

The Metric System and Equivalents

Linear Measure

1 centimeter = 10 millimeters = .39 inch
 1 decimeter = 10 centimeters = 3.94 inches
 1 meter = 10 decimeters = 39.37 inches
 1 dekameter = 10 meters = 32.8 feet
 1 hectometer = 10 dekameters = 328.08 feet
 1 kilometer = 10 hectometers = 3,280.8 feet

Weights

1 centigram = 10 milligrams = .15 grain
 1 decigram = 10 centigrams = 1.54 grains
 1 gram = 10 decigrams = .035 ounce
 1 decagram = 10 grams = .35 ounce
 1 hectogram = 10 decagrams = 3.52 ounces
 1 kilogram = 10 hectograms = 2.2 pounds
 1 quintal = 100 kilograms = 220.46 pounds
 1 metric ton = 10 quintals = 1.1 short tons

Liquid Measure

1 centiliter = 10 milliliters = .34 fl. ounce
 1 deciliter = 10 centiliters = 3.38 fl. ounces
 1 liter = 10 deciliters = 33.81 fl. ounces
 1 dekaliter = 10 liters = 2.64 gallons
 1 hectoliter = 10 dekaliters = 26.42 gallons
 1 kiloliter = 10 hectoliters = 264.18 gallons

Square Measure

1 sq. centimeter = 100 sq. millimeters = .155 sq. inch
 1 sq. decimeter = 100 sq. centimeters = 15.5 sq. inches
 1 sq. meter (centare) = 100 sq. decimeters = 10.76 sq. feet
 1 sq. dekameter (are) = 100 sq. meters = 1,076.4 sq. feet
 1 sq. hectometer (hectare) = 100 sq. dekameters = 2.47 acres
 1 sq. kilometer = 100 sq. hectometers = .386 sq. mile

Cubic Measure

1 cu. centimeter = 1000 cu. millimeters = .06 cu. inch
 1 cu. decimeter = 1000 cu. centimeters = 61.02 cu. inches
 1 cu. meter = 1000 cu. decimeters = 35.31 cu. feet

Approximate Conversion Factors

To change	To	Multiply by	To change	To	Multiply by
inches	centimeters	2.540	ounce-inches	Newton-meters	.007062
feet	meters	.305	centimeters	inches	.394
yards	meters	.914	meters	feet	3.280
miles	kilometers	1.609	meters	yards	1.094
square inches	square centimeters	6.451	kilometers	miles	.621
square feet	square meters	.093	square centimeters	square inches	.155
square yards	square meters	.836	square meters	square feet	10.764
square miles	square kilometers	2.590	square meters	square yards	1.196
acres	square hectometers	.405	square kilometers	square miles	.386
cubic feet	cubic meters	.028	square hectometers	acres	2.471
cubic yards	cubic meters	.765	cubic meters	cubic feet	35.315
fluid ounces	milliliters	29.573	cubic meters	cubic yards	1.308
pints	liters	.473	milliliters	fluid ounces	.034
quarts	liters	.946	liters	pints	2.113
gallons	liters	3.785	liters	quarts	1.057
ounces	grams	28.349	liters	gallons	.264
pounds	kilograms	.454	grams	ounces	.035
short tons	metric tons	.907	kilograms	pounds	2.205
pound-feet	Newton-meters	1.356	metric tons	short tons	1.102
pound-inches	Newton-meters	.11296			

Temperature (Exact)

°F	Fahrenheit temperature	5/9 (after subtracting 32)	Celsius temperature	°C
----	------------------------	----------------------------	---------------------	----

PIN: 065562-000